

0895BAHU

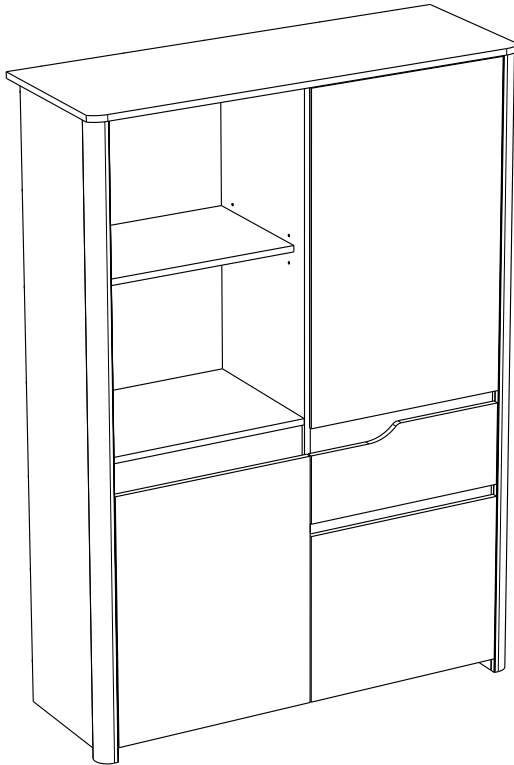

Gamme : WENDY



PARISOT INDUSTRIE

FR Remerciements :

Nous vous remercions d'avoir choisi un meuble créé et fabriqué par le Groupe Parisot et espérons qu'il vous donnera entière satisfaction.

EN Thanks:

Thank you for choosing furniture designed and manufactured by the Parisot Group.
We hope you are totally satisfied with your purchase.

DE Danksagung:

Wir danken Ihnen für den Kauf eines Frankreich von der Parisot-Gruppe entworfenen und hergestellten Möbelstücks und hoffen, dass Sie es zu Ihrer vollkommenen Zufriedenheit finden werden.

HU Köszönet:

Köszönjük, hogy a Parisot Groupe által létrehozott és gyártott bútort választott, reméljük, hogy elégedett lesz a termékkel.

PT Agradecimentos:

Obrigado por ter escolhido um móvel concebido e fabricado pelo Grupo Parisot, esperando que seja do seu inteiro agrado.

IT Ringraziamenti:

Grazie per avere scelto un mobile progettato e fabbricato dal Gruppo Parisot. Speriamo soddisfi appieno le vostre esigenze.

NL Bedankje:

Wij bedanken u voor de aankoop van een door de Groep Parisot ontworpen en vervaardigd meubel en hopen dat u er veel plezier aan zult beleven.

CZ Poděkování:

Děkujeme, že jste si vybrali nábytek navržený a vyrobený společností Parisot Group. Doufáme, že budete svým nákupem naprosto spokojeni.

ES Agradecimientos:

Les damos las gracias por haber elegido un mueble diseñado y fabricado por el Groupe Parisot y esperamos que sea de su total agrado.

PL Podziękowania:

Dziękujemy za wybór mebli stworzonych i wyprodukowanych przez Grupę Parisot. Mamy nadzieję, że będziecie Państwo w pełni zadowoleni z zakupu.

SK Pod'akovanie:

Ďakujeme, že ste si vybrali nábytok navrhnutý a vyrobený spoločnosťou Parisot Group. Dúfame, že budete svojím nákupom absolútne spokojní.

AR شكر:

نشكركم لاختياركم هذه القطعة من الأثاث من تصميم وتصنيع مجموعة باريسو Parisot ونتمنى أن تتال رضاهكم.

PARISOT INDUSTRIE

15 Avenue Jacques Parisot, 70800 Saint-Loup sur Semouse
contact@parisot.com
RCS VESOUL 537 665 200

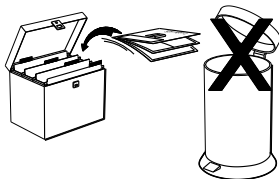

FR

Donnez ou recyclez
vos meubles.



Association



Magasin



Déchèterie

<https://quefairedemesdechets.fr>

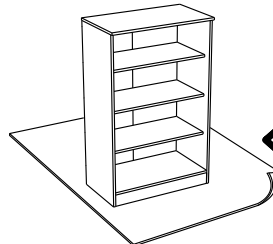
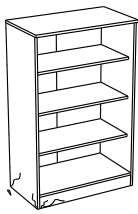
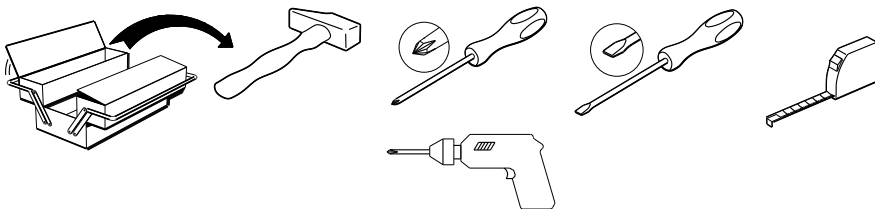

FR: INSTRUCTIONS GÉNÉRALES POUR LE MOBILIER CONSTITUÉ DE BOIS OU DE COMPOSITES DE BOIS (COMME LES SURFACES EN MELAMINÉ, STRATIFIÉ OU PLACAGE)

Nettoyer à l'aide d'un chiffon humide. Utiliser uniquement de l'eau ou un détergent doux.

Essuyer à l'aide d'un chiffon propre.

Pour une stabilité optimale, resserrer les vis et autres fixations lorsque nécessaire.

EN: GENERAL INSTRUCTION FOR FURNITURE MADE OF WOOD OR WOOD COMPOSITES SUCH AS MELAMINE, LAMINATE OR VENEER SURFACES

Wipe clean with a damp cloth. Use only water or a gentle detergent.

Wipe dry with a clean cloth.

For increased stability, re-tighten the screws and other connectors when necessary.

DE: ALLGEMEINE ANWEISUNGEN FÜR MÖBELPFLEGE AUS HOLZ ODER HOLZVERBUNDWERKSTOFFEN (WIE MELAMIN-, LAMINA T- ODER FURNIEROBERFLÄCHEN)

Mit einem feuchten Tuch reinigen. Verwenden Sie nur Wasser oder ein mildes Reinigungsmittel.

Mit einem sauberen Tuch abwischen.

Zur Erhöhung der Stabilität die Schrauben und anderen Verbindungsstücke bei Bedarf nachziehen.

HU: ÁLTALÁNOS ÚTMUTATÁS A FÁBÓL KÉSZÜLT VAGY ÖSSZETETT FAANYAGOT, PÉLDÁUL MELAMIN-, LAMINÁLT VAGY FURNÉRFELÜLETET TARTALMAZÓ BÚTOROKHOZ

Törölje tisztára nedves ruhával. Csak vizet vagy kímélő tisztítószeret használjon.

Törölje szárazra tiszta ruhával.

A nagyobb stabilitás érdekében szükség esetén húzd meg újra a csavarokat és egyéb összekötő elemeket.

PT: INSTRUÇÕES GERAIS PARA OS MOVÉIS DE MADEIRA, LAMINADO, MELAMINA E FOLHEADO.

Limpar com um pano húmido, utilizar apenas água ou detergente doce.

Limpar com um pano seco.

Para uma maior estabilidade, volte a apertar os parafusos e outros conetores sempre que necessário.

IT: ISTRUZIONI GENERALI PER MOBILI IN LEGNO O MATERIALI COMPOSITI IN LEGNO (COME SUPERFICI IN MELAMINICO, LAMINATO O IMPIALLACCIATO)

Pulire con un panno umido. Utilizzare solo acqua o un detergente delicato.

Asciugare con un panno pulito.

Per una maggiore stabilità, stringi nuovamente le viti e gli altri elementi di fissaggio quando necessario.

NL: ALGEMENE INSTRUCTIES VOOR MEUBELS VERVAARDIGD UIT HOUT OF HOUTCOMPOSIT ALS MELAMINE, LAMINAAT OF FINEEROPPERVLAKKEN!

Reinig met een vochtige doek. Gebruik alleen water of wasmiddel.

Droogwrijven met een schone doek.

Voor extra stevigheid de schroeven en andere verbindingen nogmaals aandraaien wanneer nodig.

CZ: OBEČNÉ POKYNY TÝKAJÍCÍ SE NÁBYTKU VYROBENÉHO ZE DŘEVA NEBO Z KOMPOZITŮ DŘEVA, NAPŘ. S POVRCHEM Z MELAMINU, LAMINÁTU NEBO DYHY!

Čistěte otřením navlhčeným hadříkem. Používejte pouze vodu nebo jemný čistící prostředek.

Vytřete dosucha čistým hadříkem.

Pro zvýšení stability šrouby a další spojovací díly v případě potřeby dotáhněte.

ES: INSTRUCCIONES GENERALES PARA MUEBLES FABRICADOS CON MADERA, MELAMINA, LAMINADO Y CHAPA.

Limpiar con pano húmedo. Utilizar únicamente agua o detergente suave.

Secar con un paño seco.

Para mayor estabilidad, aprieta de nuevo los tornillos y otros conectores cuando sea necesario.

PL: OGÓLNE INSTRUKCJE DOTYCZĄCE MEBLI Z DREWNA ORAZ MATERIAŁÓW DREWNOPOCHODNYCH : MELAMINA, LAMINAT, OKLEINA

Do czyszczenia należy używać wilgotnej ściereczki. Używać wyłącznie wody lub delikatnego detergentu.

Wycierać do sucha ściereczką.

Aby uzyskać optymalną stabilność, w razie potrzeby dokręć śruby i inne elementy mocujące.

SK: VŠEOBECNÉ POKYNY PRE NÁBYTOK VYROBENÝ Z DREVA ALEBO KOMPOZITNÝCH MATERIÁLOV, NAPRIKAD MELAMINU, LAMINÁTU ALEBO PREGLEJKOVÝCH POVRCHOV!

Utrite dočista navlhčenou utierkou. Používajte iba vodu alebo jemný čistiaci prostriedok.

Utrite dosucha čistou utierkou.

Na zvýšenie stability v prípade potreby opätovne utiahnite skrutky a ostatné spojovacie prvky.

AR: تعليمات عامة للأثاث المصنوع من الخشب أو الخشب المركبات مثل الميلامين أو الصفانج أو الأسطح الخشبية

امسحي بقطعة قماش مبللة. استخدم الماء أو المنظف اللطيف فقط. يجف بقطعة قماش نظيفة.

لمزيد من الثبات، أعد ربط المسامير والوصلات الأخرى عند الضرورة.

151.5cm
59 3/4"
109cm
43"
40cm
15 3/4"

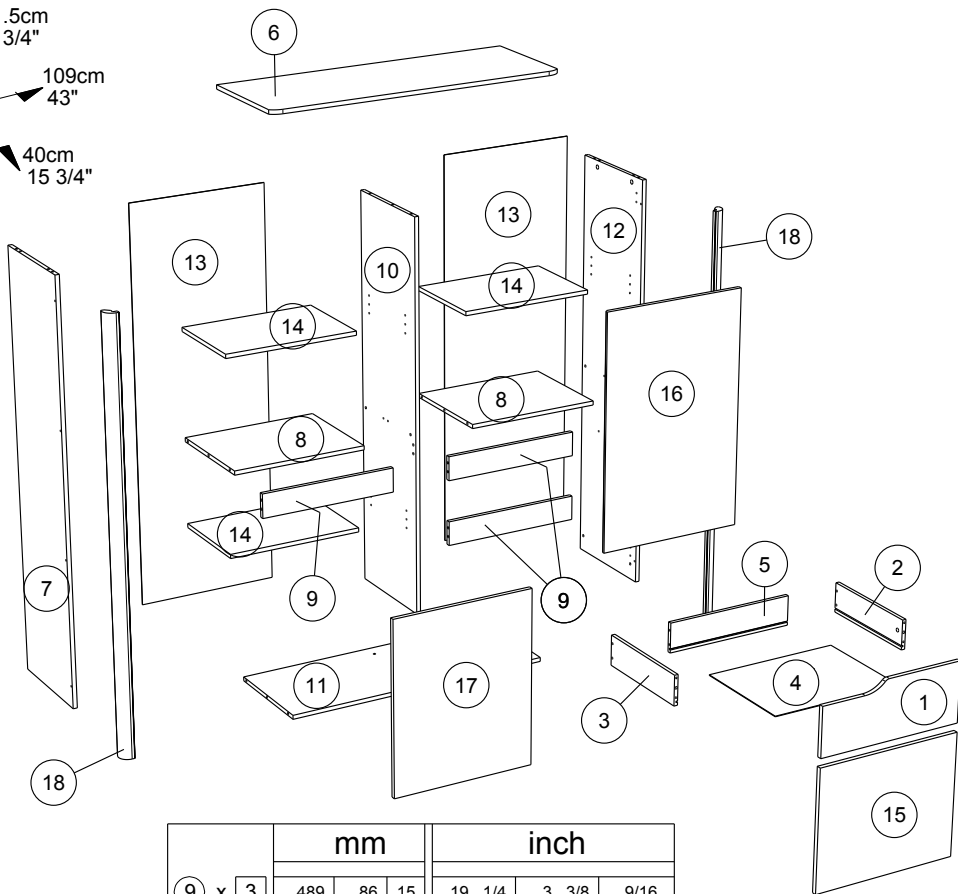

		mm			inch		
9	x 3	489	86	15	19 1/4	3 3/8	9/16
14	x 3	489	330	15	19 1/4	13	9/16
8	x 2	489	376	15	19 1/4	14 13/16	9/16
1	x 1	493	200	15	19 3/8	7 7/8	9/16
15	x 1	494	408	15	19 7/16	16 1/16	9/16
17	x 1	603	494	15	23 3/4	19 7/16	9/16
16	x 1	794	494	15	31 1/4	19 7/16	9/16
11	x 1	993	377	15	39 1/8	14 13/16	9/16
6	x 1	1089	396	15	42 7/8	15 9/16	9/16
10	x 1	1435	377	15	56 1/2	14 13/16	9/16
18	x 2	1500	60	28	59 1/16	2 3/8	1 1/16
7	x 1	1500	377	15	59 1/16	14 13/16	9/16
12	x 1	1500	377	15	59 1/16	14 13/16	9/16
2	x 1	350	100	13	13 3/4	3 15/16	1/2
3	x 1	350	100	13	13 3/4	3 15/16	1/2
5	x 1	439	100	13	17 5/16	3 15/16	1/2
4	x 1	451	349	2	17 3/4	13 3/4	1/16
13	x 2	1463	510	2	57 5/8	20 1/16	1/16

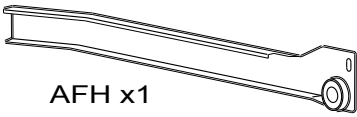

AFH x1

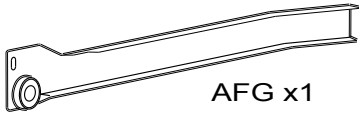

AFG x1



FA x4

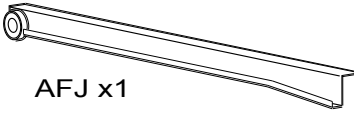

AFJ x1

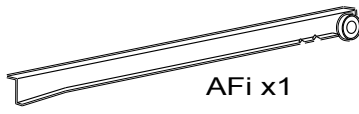

AFi x1



BZG x2



Ai x11

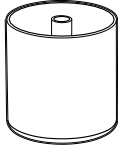

APT x1

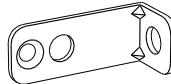

BLL x1

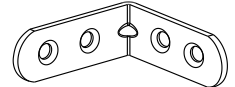

LN x2

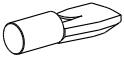

BWD x12

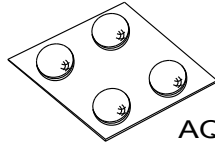

AQO x1



HV x1

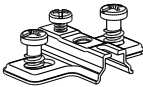

BWU x6

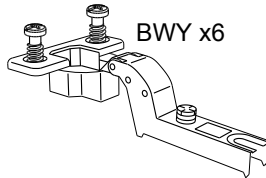

BWY x6

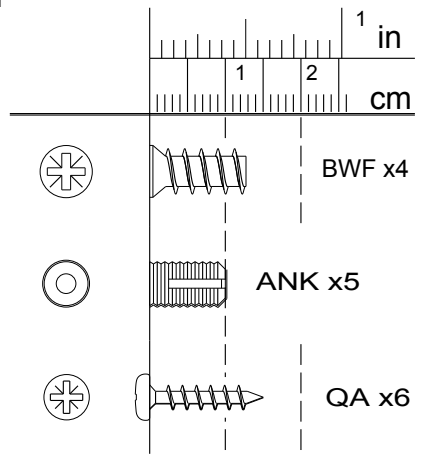
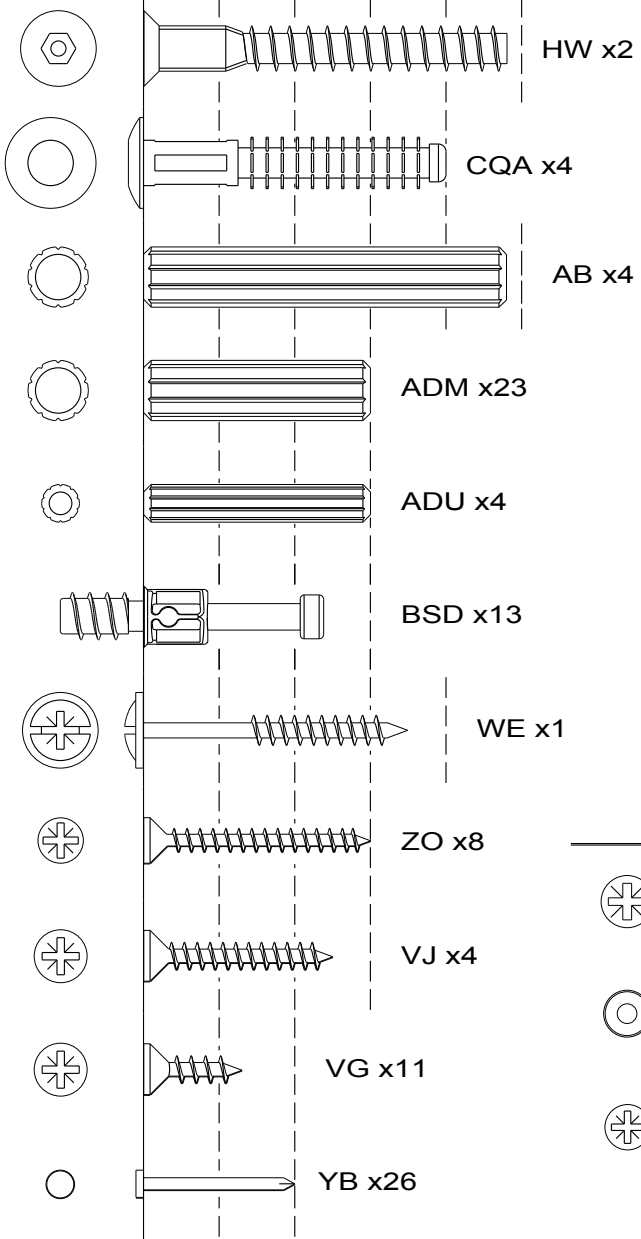
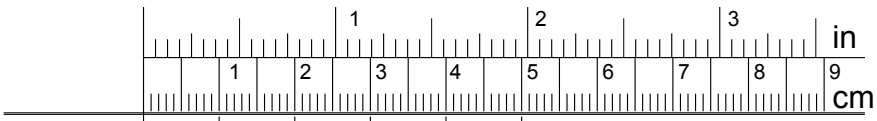

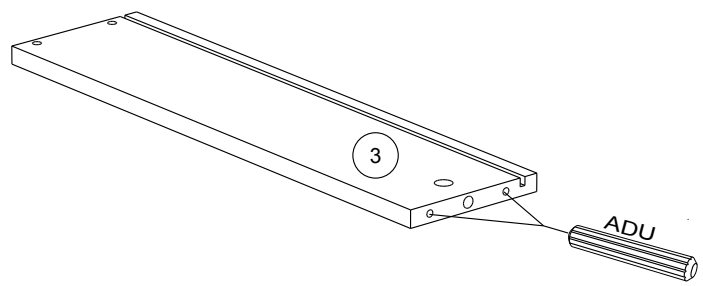
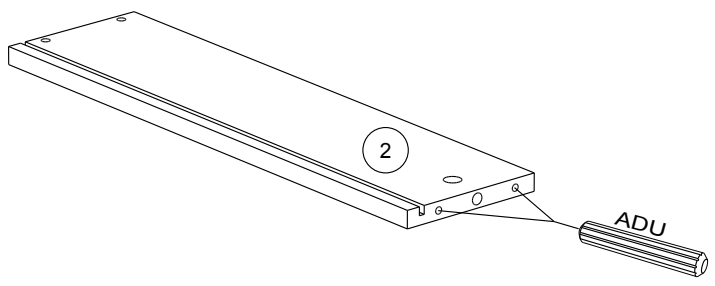
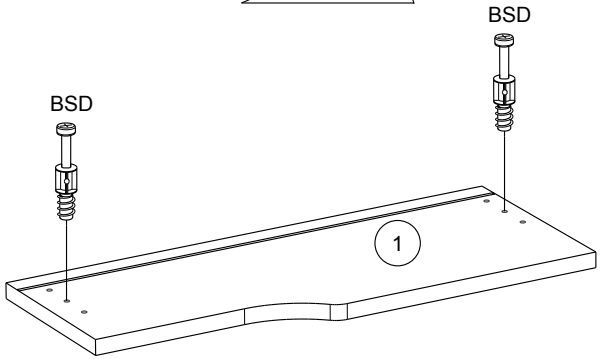
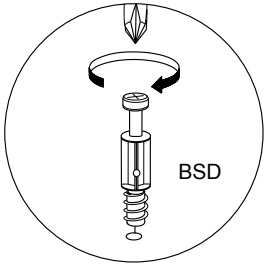
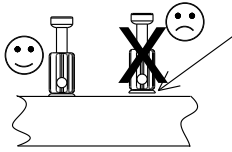
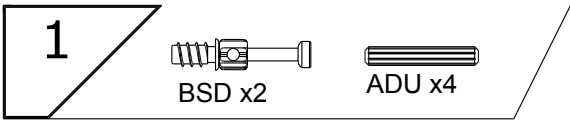

2



BZG x2



CQA x4

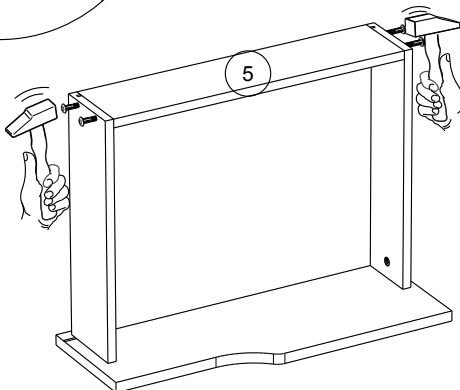
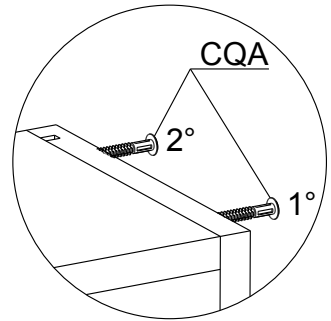
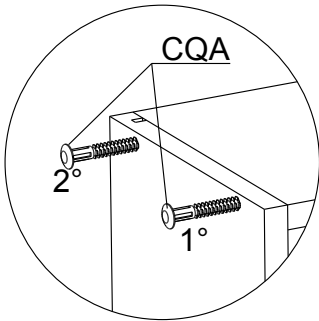
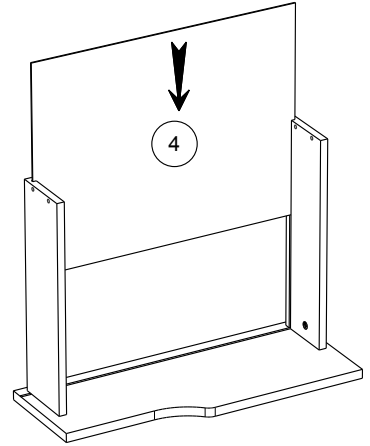
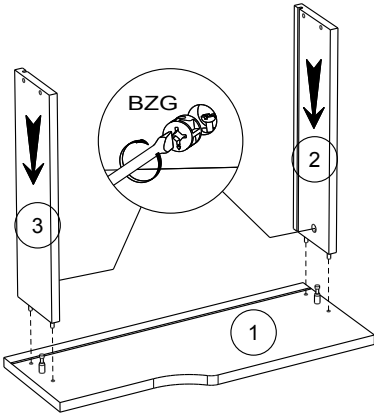

3



BSD x5

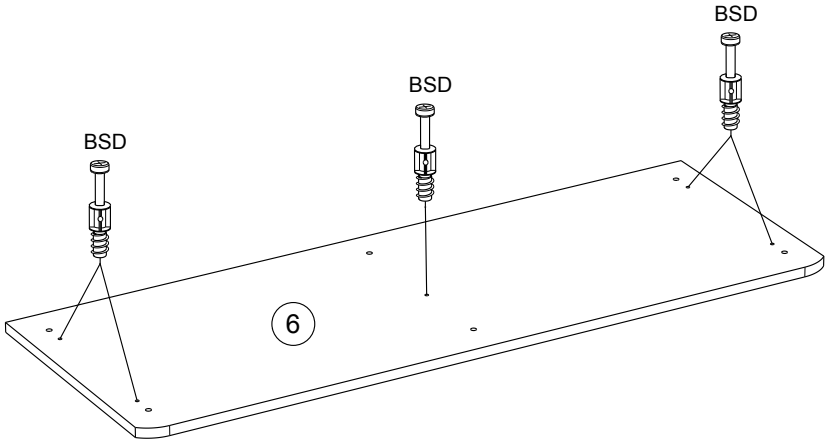

4

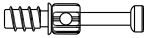

BSD x2



ADM x2



BWU x2

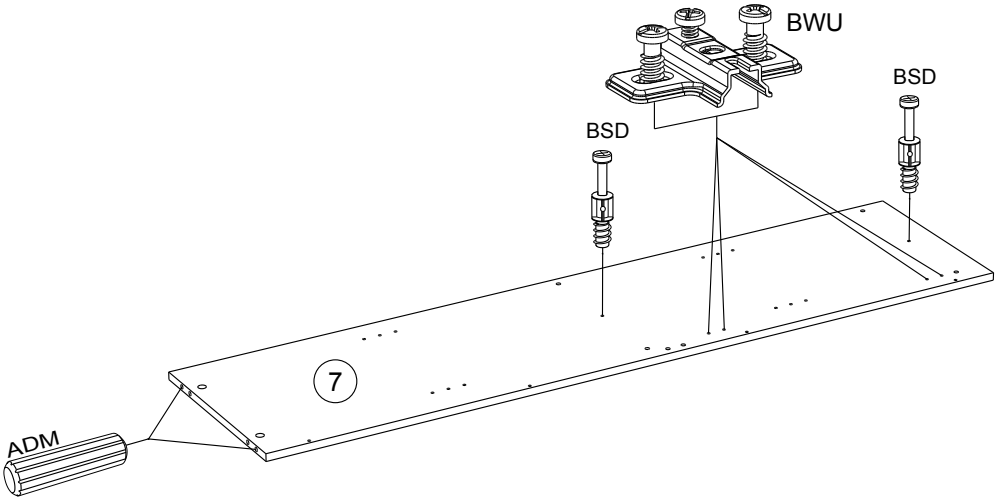

5

ADM x8

ANK x3

ANK

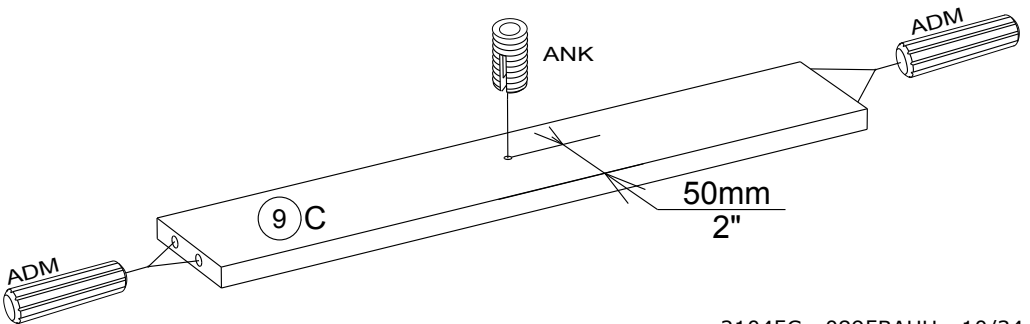
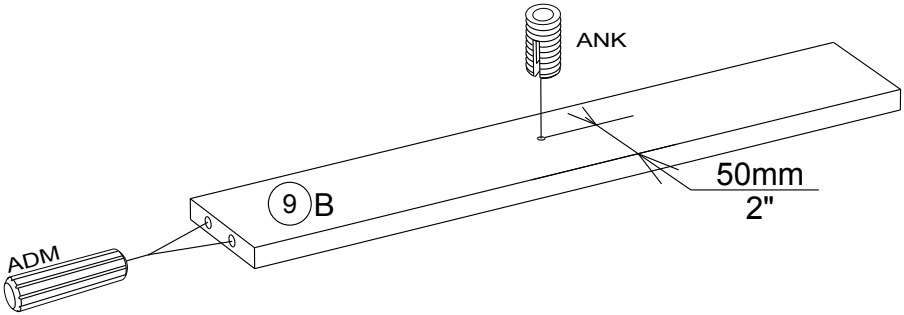
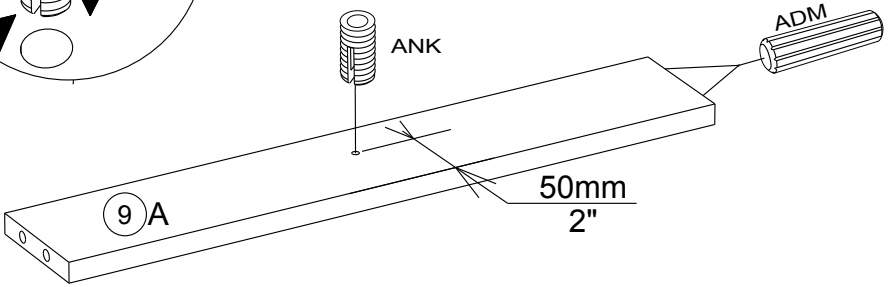
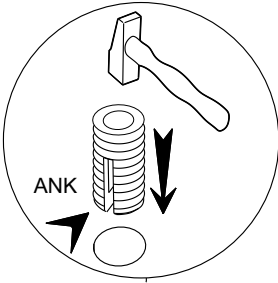
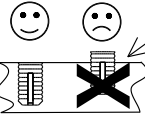

6

ADM x4 ANK x2

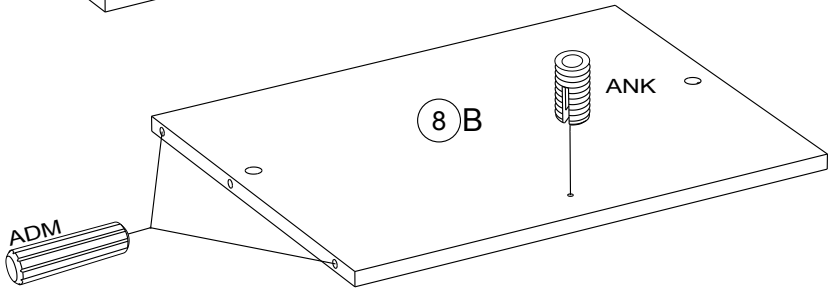
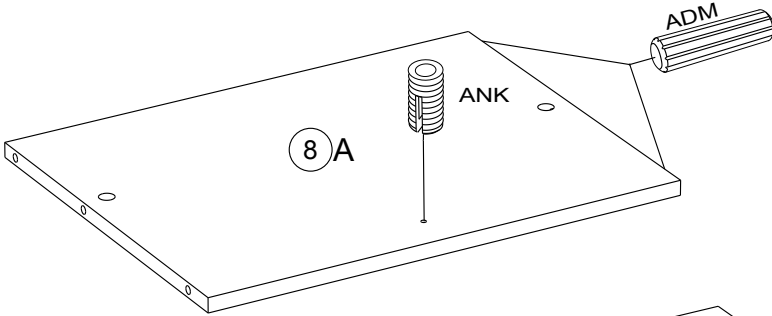
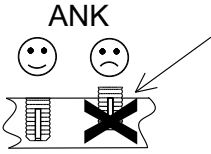
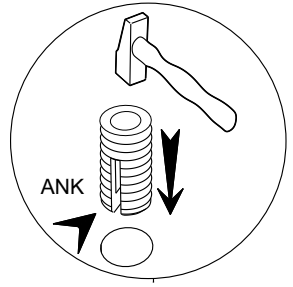

7

ADM x4

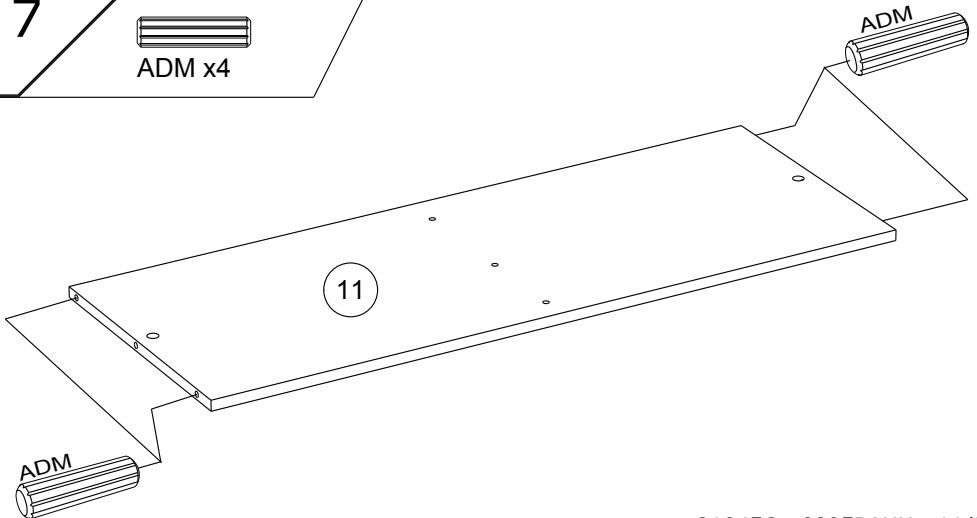

8

BSD x2

AFG x1

BWF x2

VG x1

ADM x3

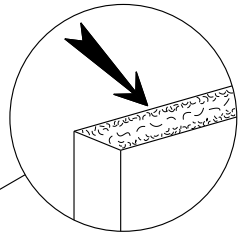

BSD

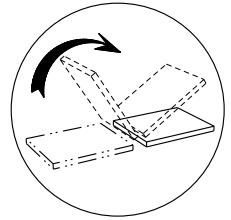
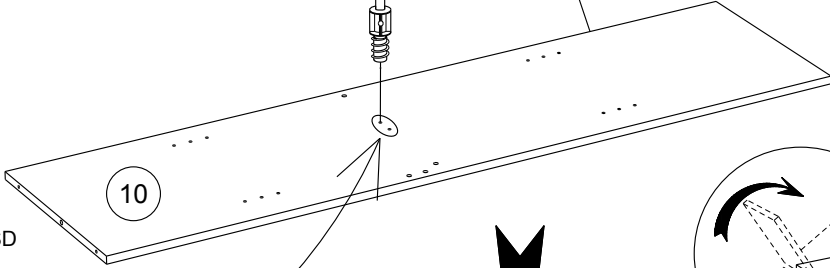

BSD

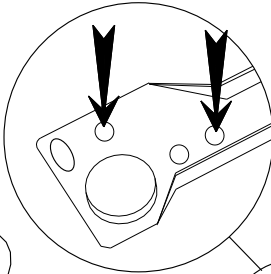
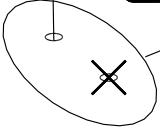

VG

BWF

AFG



BSD

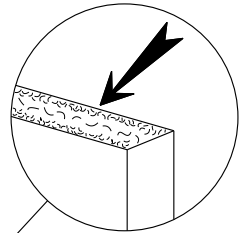
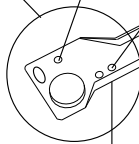
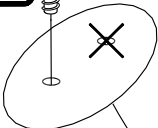

ADM

BSD

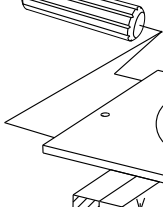

10

30mm
1 3/16"

ADM

9



ADM x2



AFH x1



BWU x4

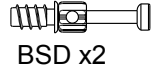

BSD x2



BWF x2



VG x1

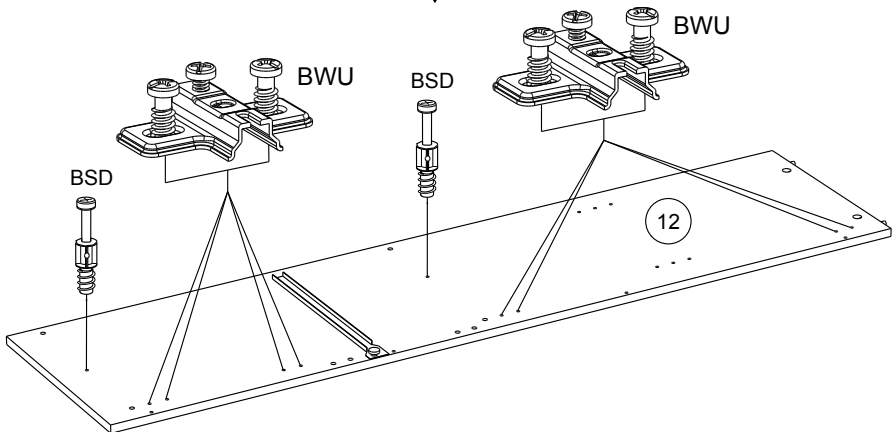
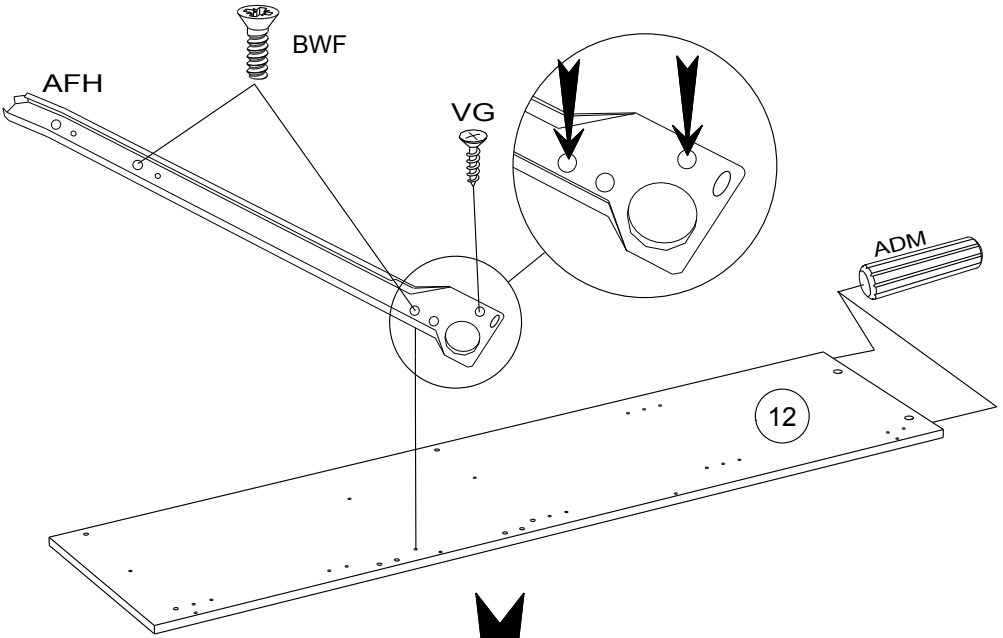

10



Ai x2

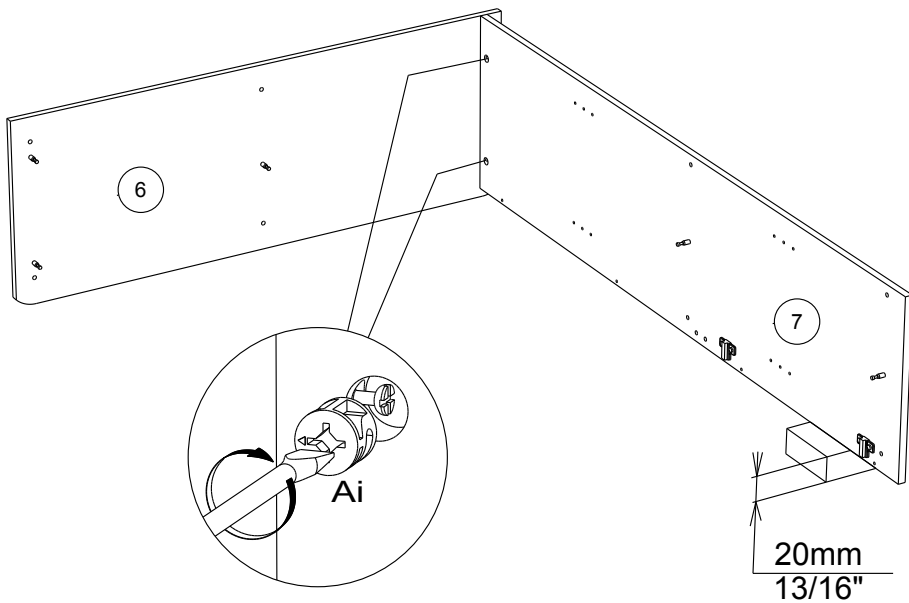

11



Ai x1

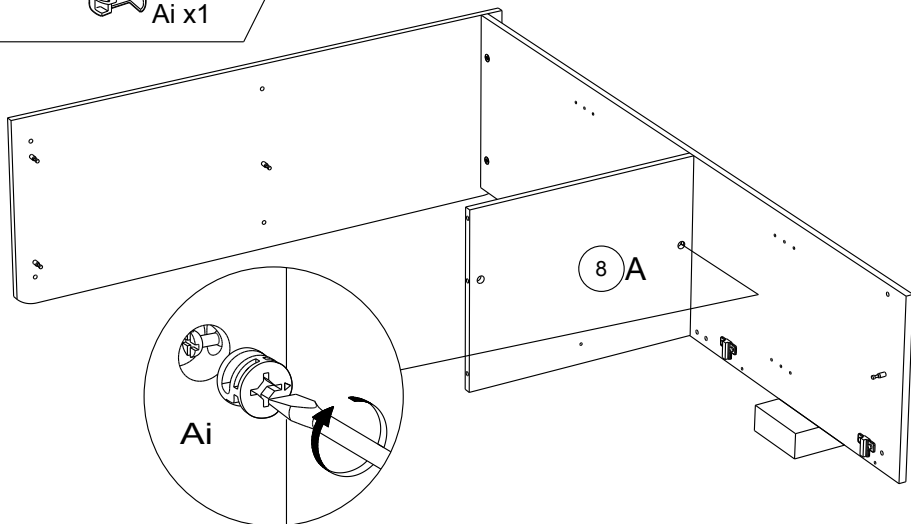

12



LN x1



VG x2

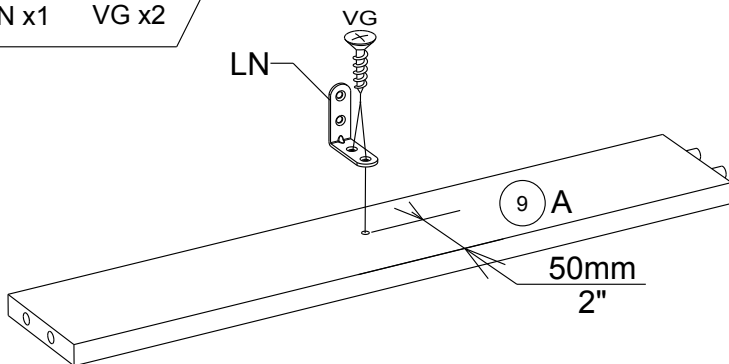

13



VG x2

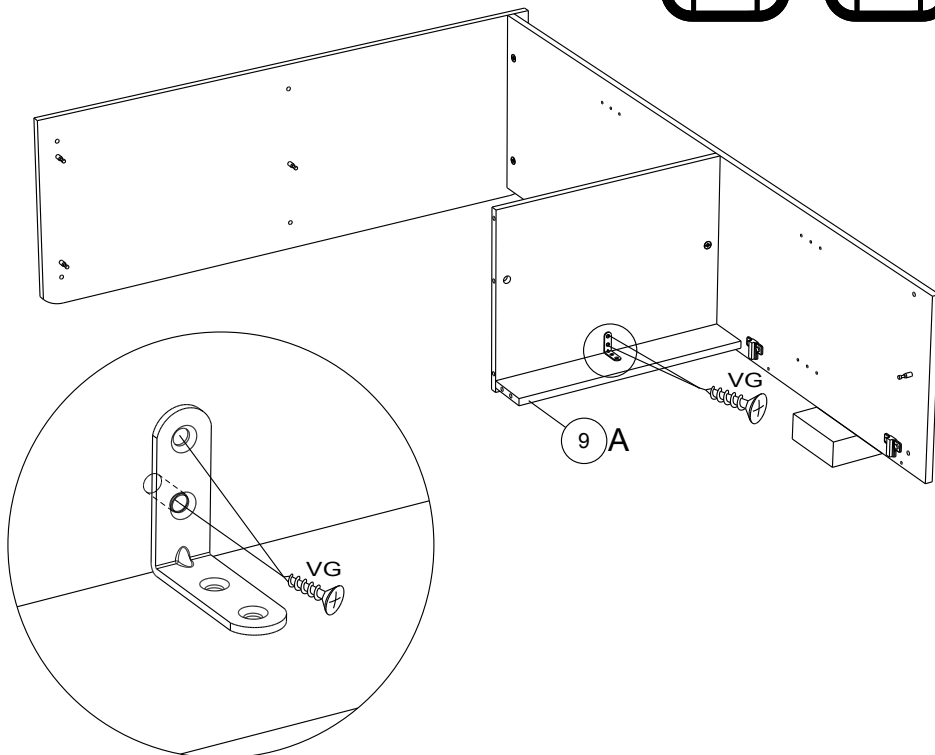
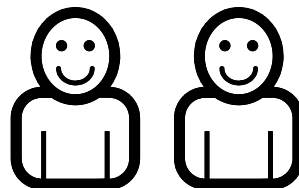

14



Ai x2

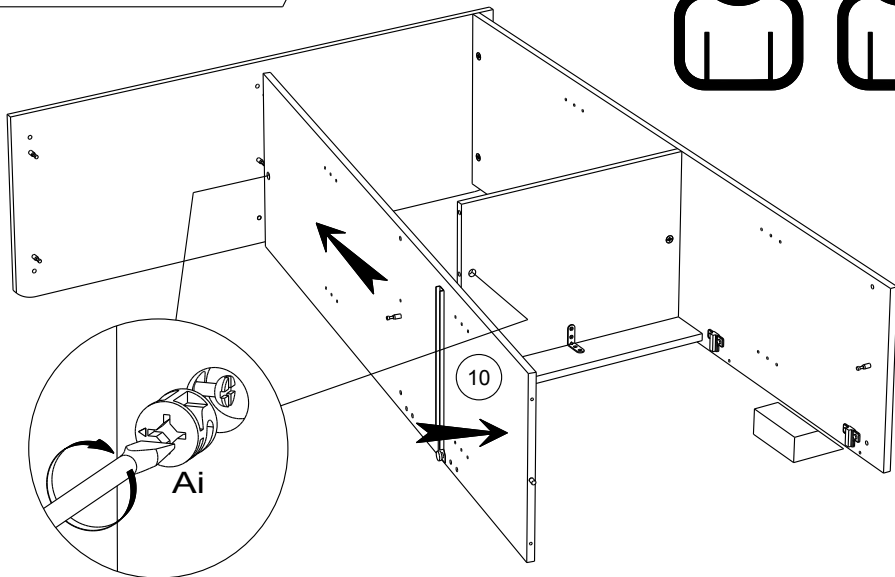
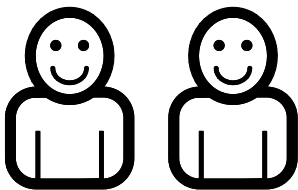

15



AB x4

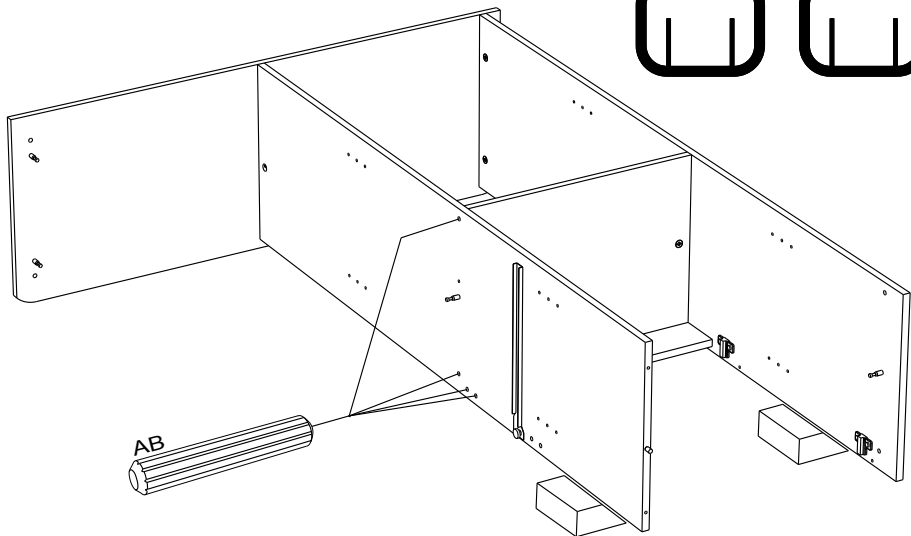
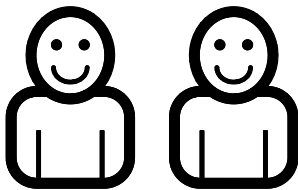

16



Ai x1

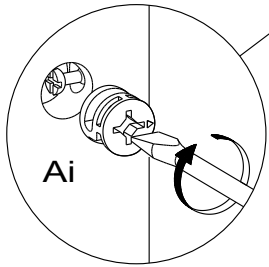
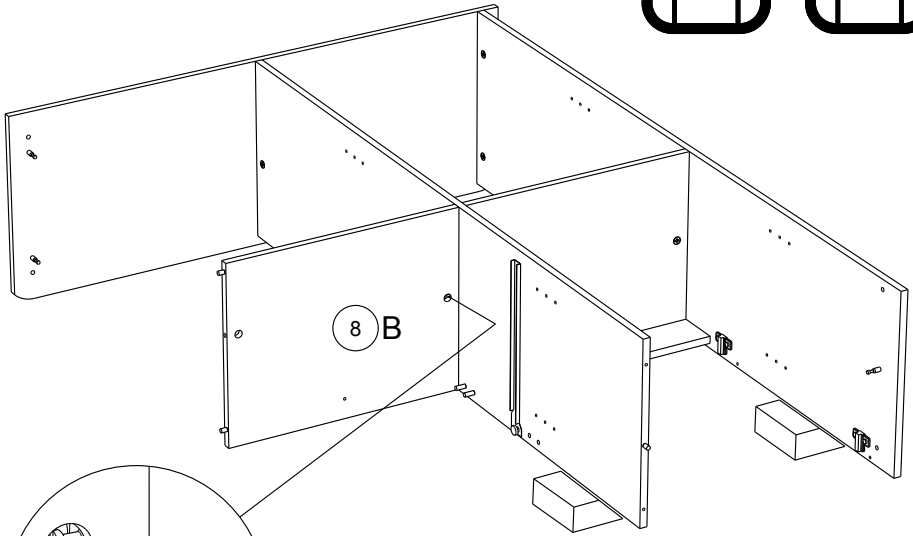
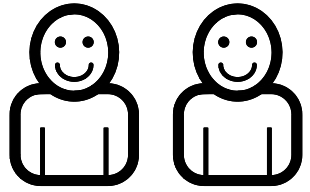

17

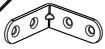

LN x1



VG x2

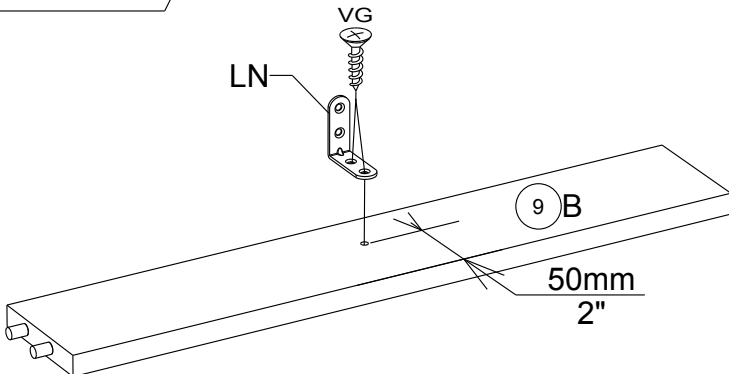

18

VG x2

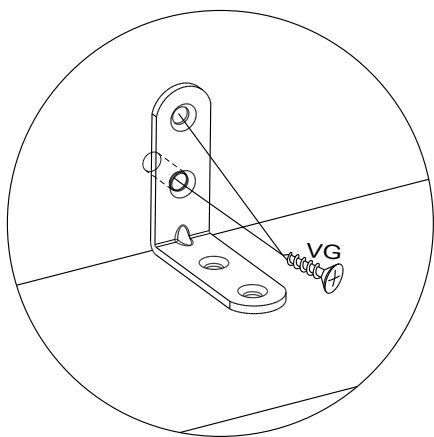
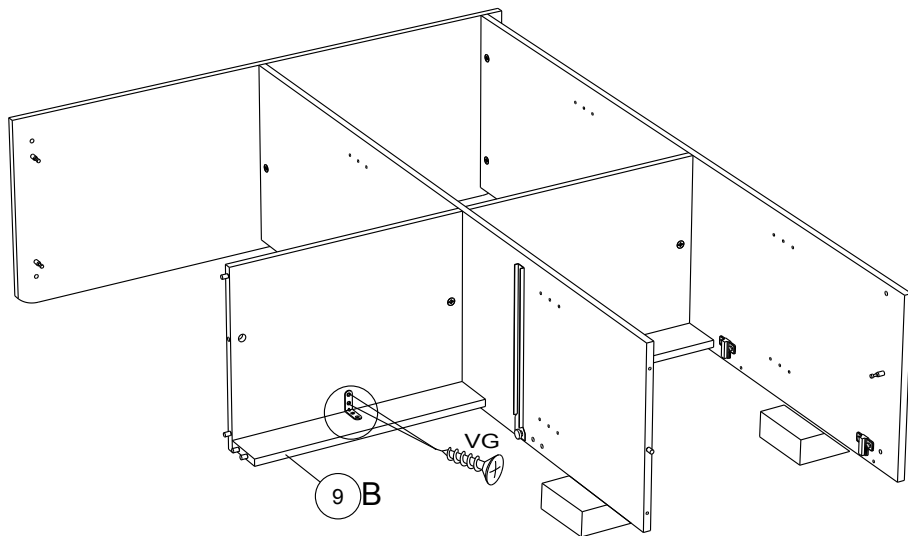
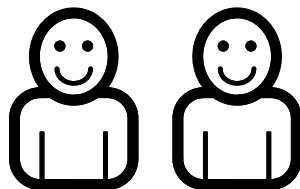

19

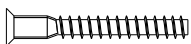

HW x2



HV x1



Ai x1

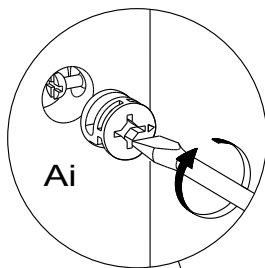

Ai

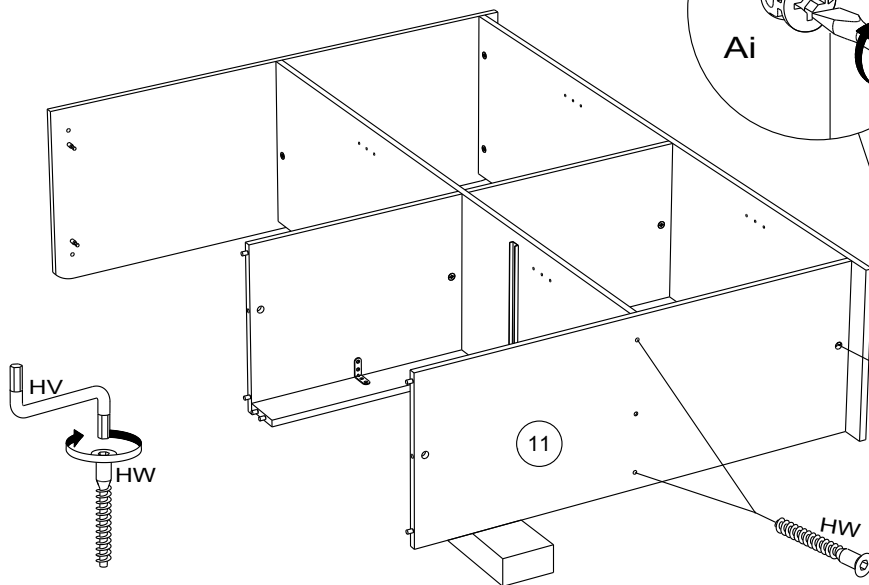

20

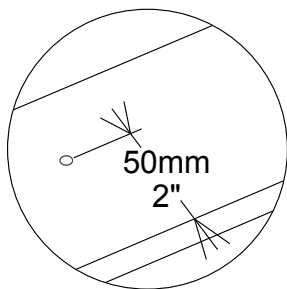
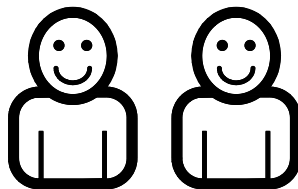

50mm
2"

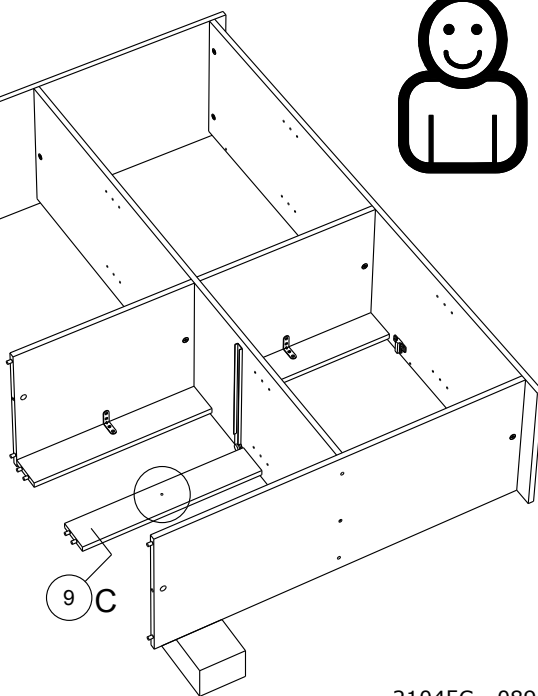

9 C

21



Ai x4

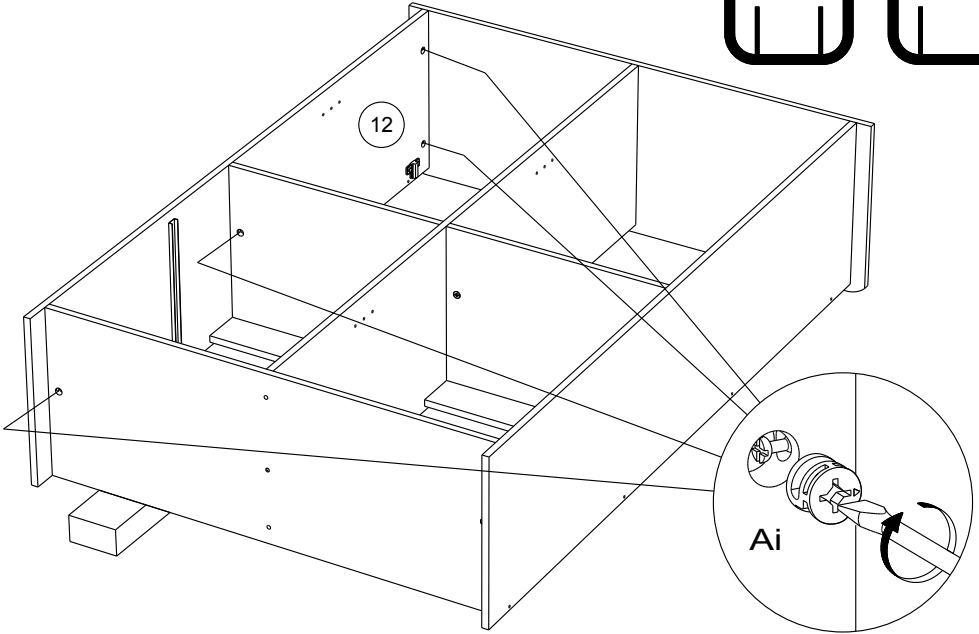
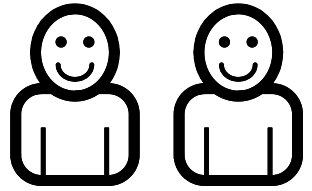

22

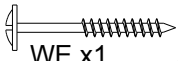

WE x1



APT x1

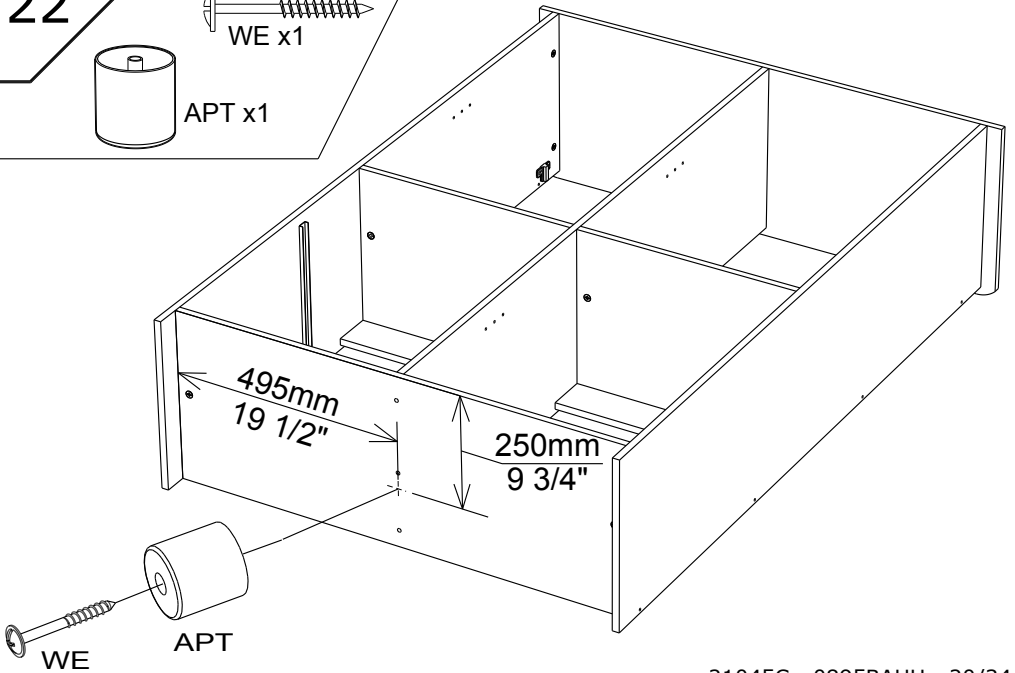

23



YB x26

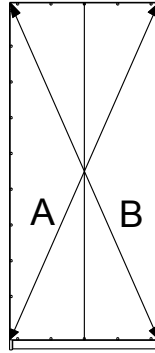

A = B

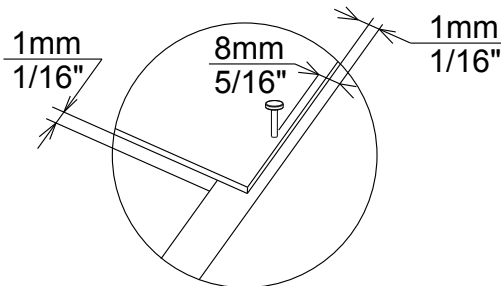
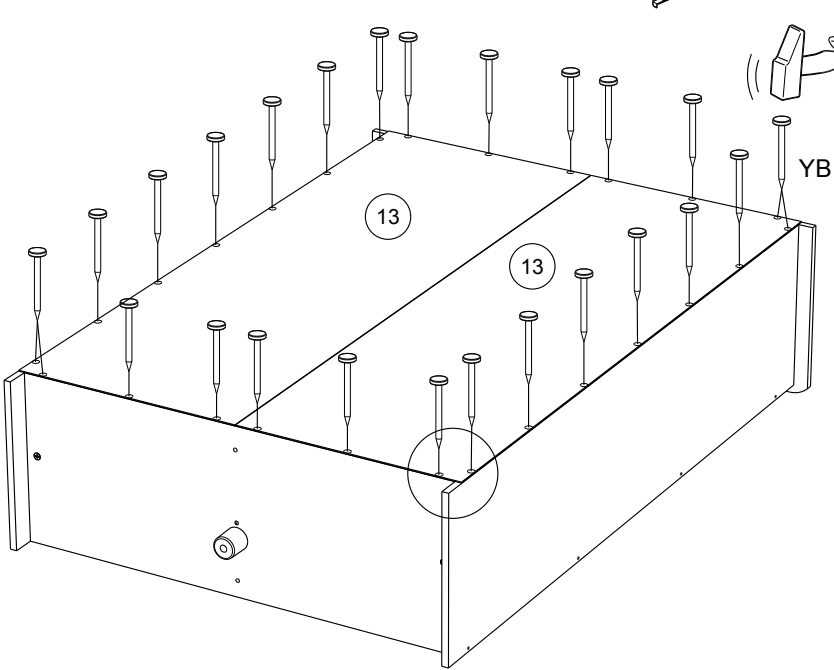

24



FA x4

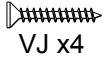

VJ x4

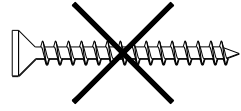

ZO

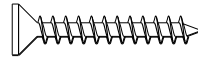

VJ

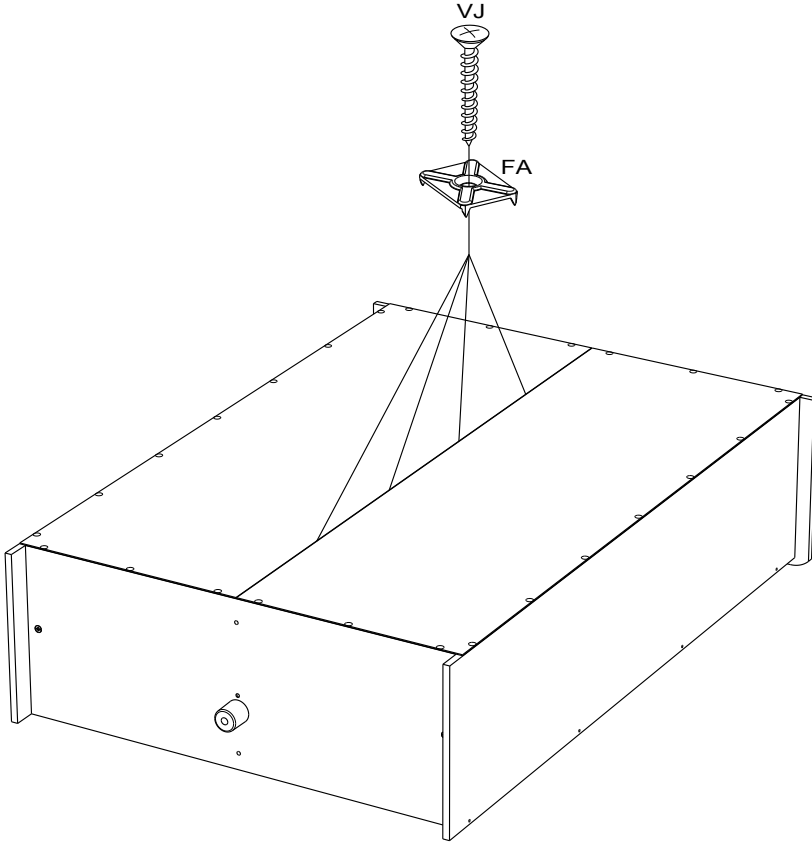

25

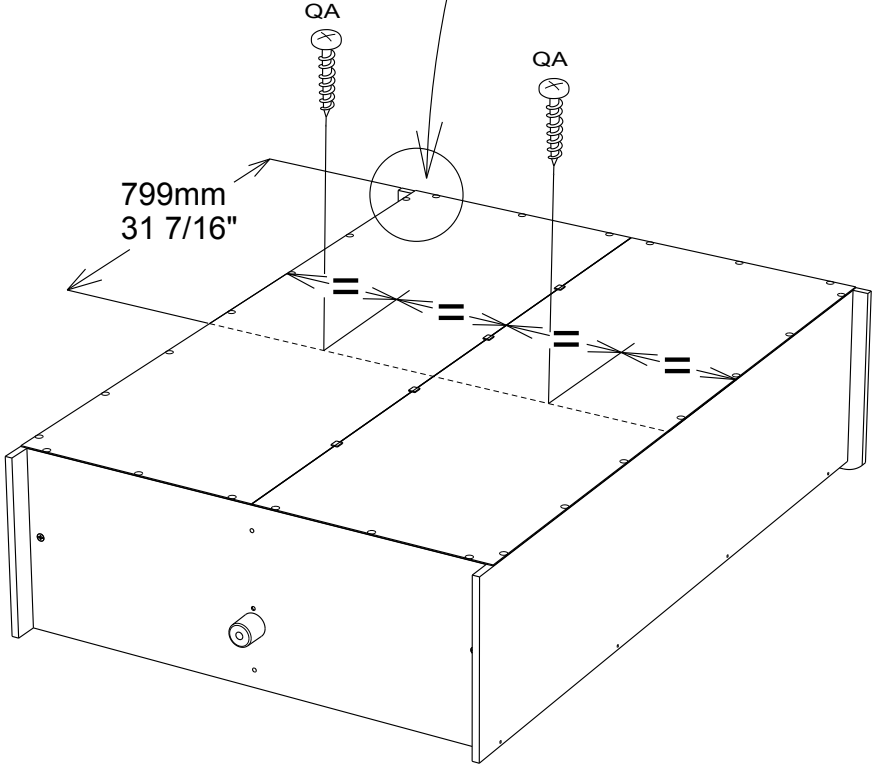
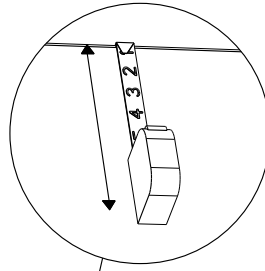
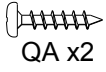

- FR OBLIGATOIRE:** Pour votre sécurité, fixation du meuble au mur.
Attention, la fixation doit être réalisée par une personne compétente car cela nécessite des chevilles et des vis adaptées à la nature de votre mur. (non fournies)
- EN OBLIGATORY:** For your safety, due to risk of overturning, this product must be used with the wall attachment device provided, this should be carried out by a competent person.
- DE OBLIGATORISCH:** Zu Ihrer Sicherheit, befestigen Sie das Möbel an der Wand.
Achtung: Diese Befestigung ist durch eine fachlich kompetente Person vorzunehmen.
Hierfür sind für die Bauweise Ihrer Wand geeignete Dübel einzusetzen.
- ES OBLIGATORIO:** Por su seguridad, fijar el mueble a la pared.
Advertencia: la fijación la ha de llevar a cabo por personal adecuado, ya que requiere el uso de tacos que se adapten al tipo de pared.
- PT OBRIGATÓRIO:** Para sua segurança, fixação do móvel ao muro.
Atenção: a fixação deverá ser efetuada por pessoa habilitada, visto que são necessárias cavilhas adaptadas ao tipo de parede.
- IT OBBLIGATORIO:** Avvertenza di sicurezza, il fissaggio del mobile a parete deve essere realizzato da una persona competente, in quanto l'operazione richiede l'impiego di tasselli adatti alla natura del muro.
- NL VERPLICHT:** Voor uw veiligheid, bevestiging van het meubel aan de muur.
Opgelet de bevestiging moet worden uitgevoerd door een bekwaam persoon daar dit voor uw type muur geschikte pluggen vereist.
- CZ POVINNÝ:** Z bezpečnostních důvodů, upevněte nábytek do zdi.
Pozor, upevnění je třeba svěřit kompetentní osobě, neboť vyžaduje hmoždinky vhodné pro vaši zeď.
- HU KÖTELEZŐ:** Az Ön biztonsága érdekében, a bútor falra rögzítése.
Figyelmeztetés : a rögzítés csak megfelelő szakképesítéssel rendelkező személy által végezhető el, mert a rögzítéshez a falnak megfelelő csavarokra van szükség.
- PL OBOWIĄZKOWY:** Dla bezpieczeństwa, mocowanie mebla do ściany.
Uwaga, mocowanie musi zostać wykonane przez osobę kompetentną, ponieważ wymaga to zastosowania kołków dostosowanych do rodzaju ściany.
- SK POVINNÉ:** Z bezpečnostných dôvodov, nábytok upevnite k stene.
Dbajte na to, aby upevnenie vykonala kompetentná osoba, pretože pri upevňovaní sa vyžadujú kolíky vhodné do materiálu, z ktorého je stena vyrobená.
- EL ΥΠΟΧΡΕΩΤΙΚΟΣ :** Για την ασφάλειά σας στερέωση των επίπλων στον τοίχο.
Προσοχή, η στερέωση πρέπει να γίνεται από ικανό άτομο, καθώς απαιτούνται σφηνές προσαρμοσμένες στη φύση του τοίχου σας.

AR واجب : لسلامتك الشخصية, تثبيت قطعة الأثاث على الحائط
تحذير، يجب أن يقوم شخص متخصص بعملية التثبيت على الحائط إذ أنها تتطلب اسفينا معيناً يتوافق مع طبيعة الحائط نفسه.

26

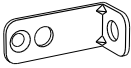

BLL x1



VG x1

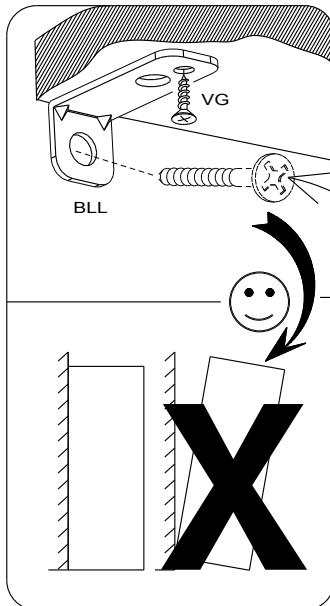
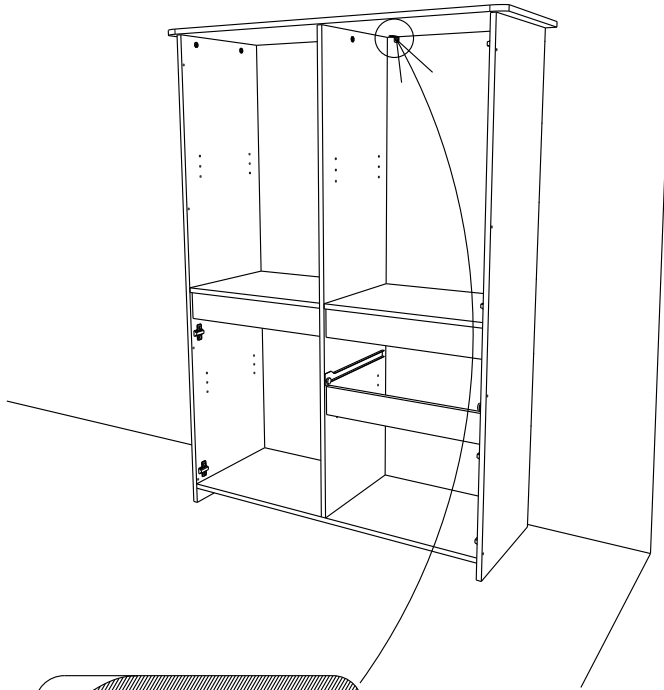

NON INCLUE.
NO INCLUIDO.
NOT INCLUDED.
WERDEN NICHT.
MITGELIEFERT.
NIET INBEGREPEN.
DAHIL DEGIL.

27



BWD x12

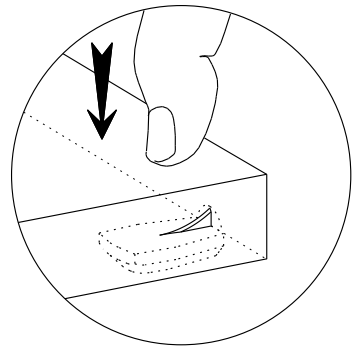
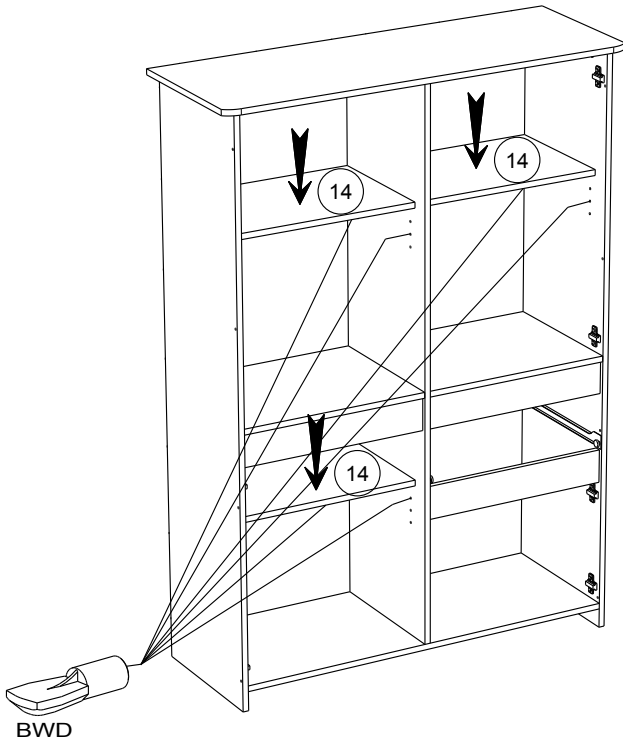
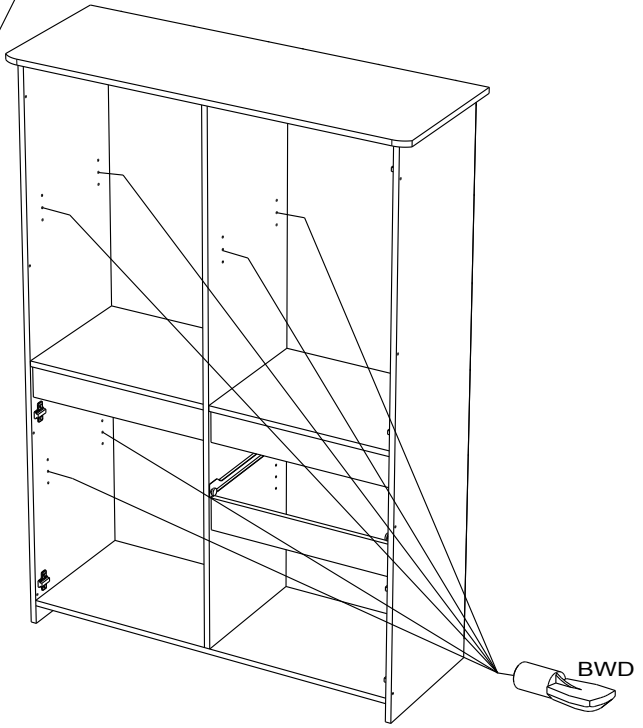

28

BWY x6

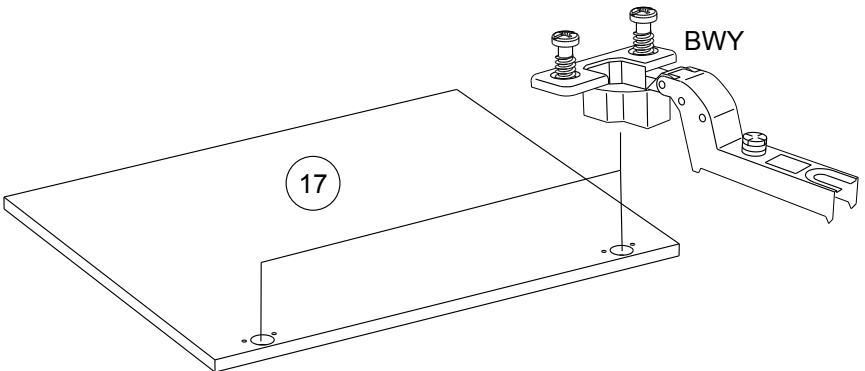
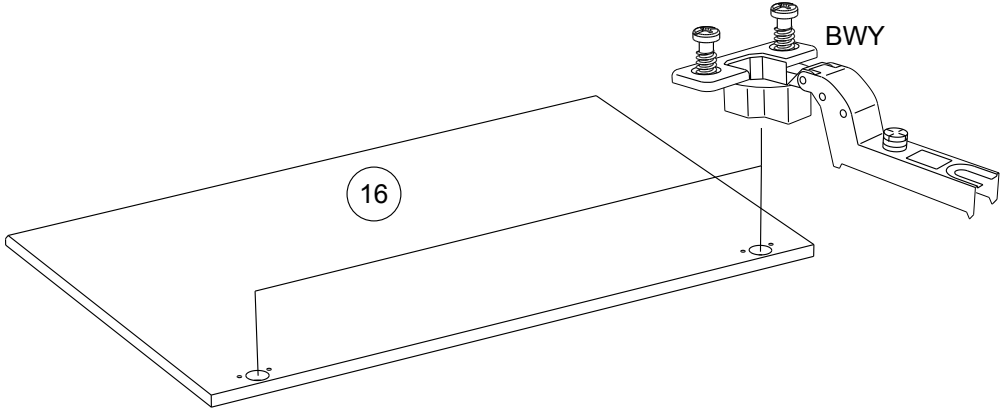
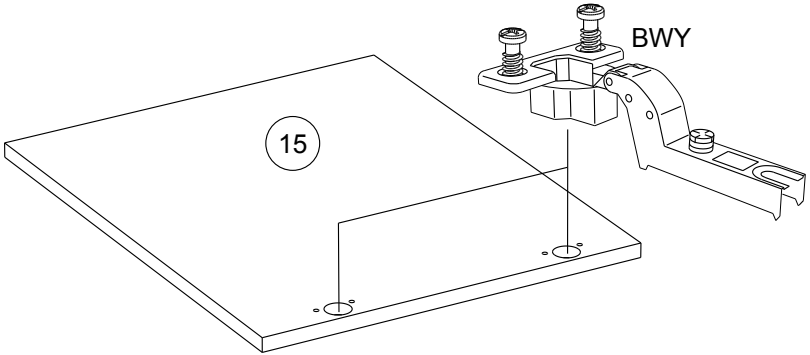
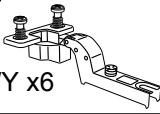

29

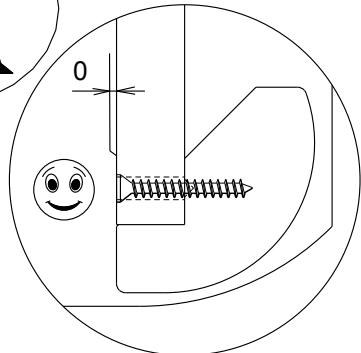
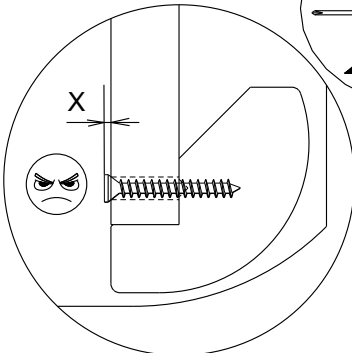
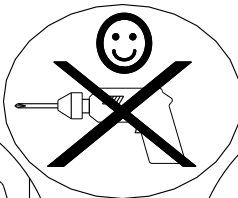
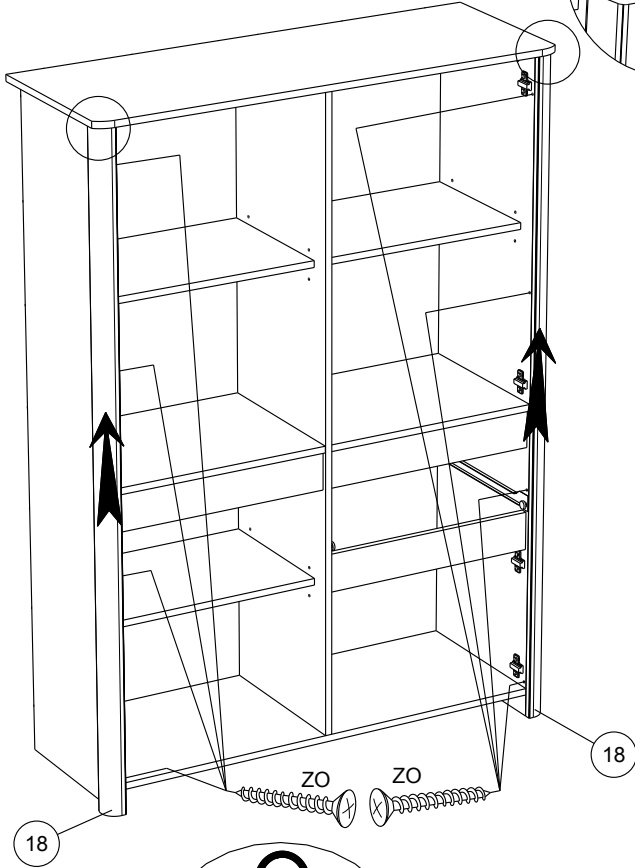
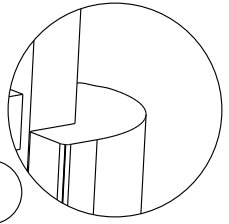
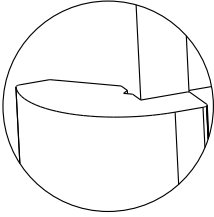
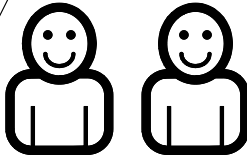
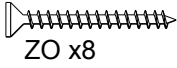

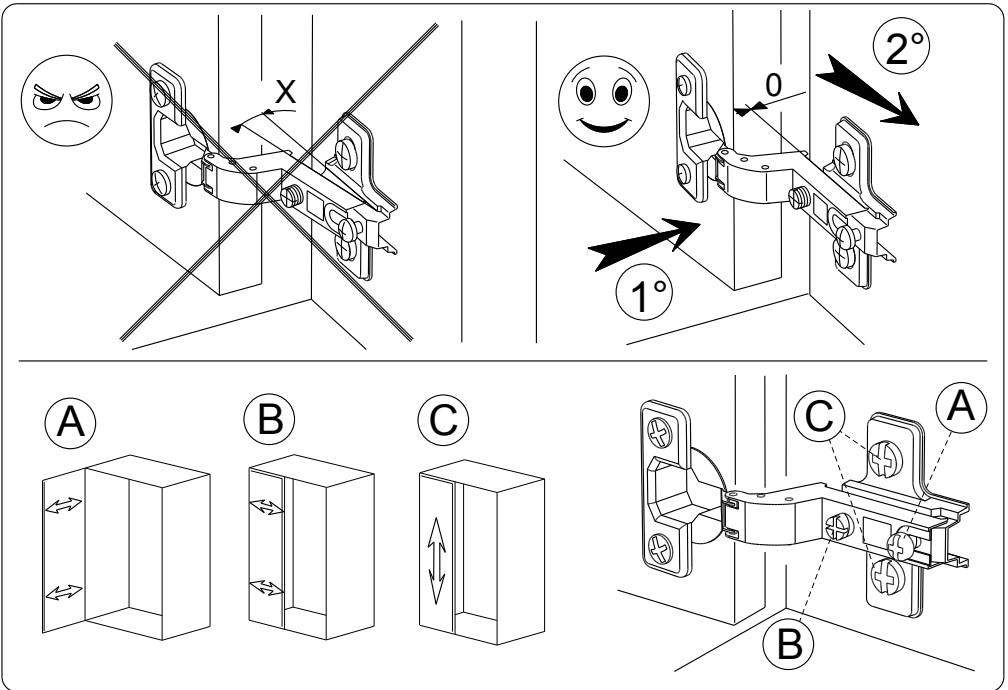
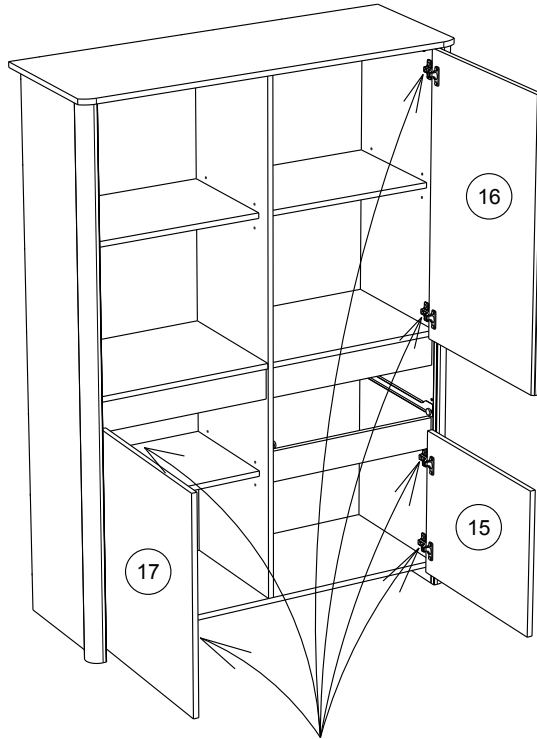

31

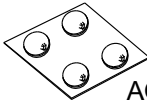

AQO x1

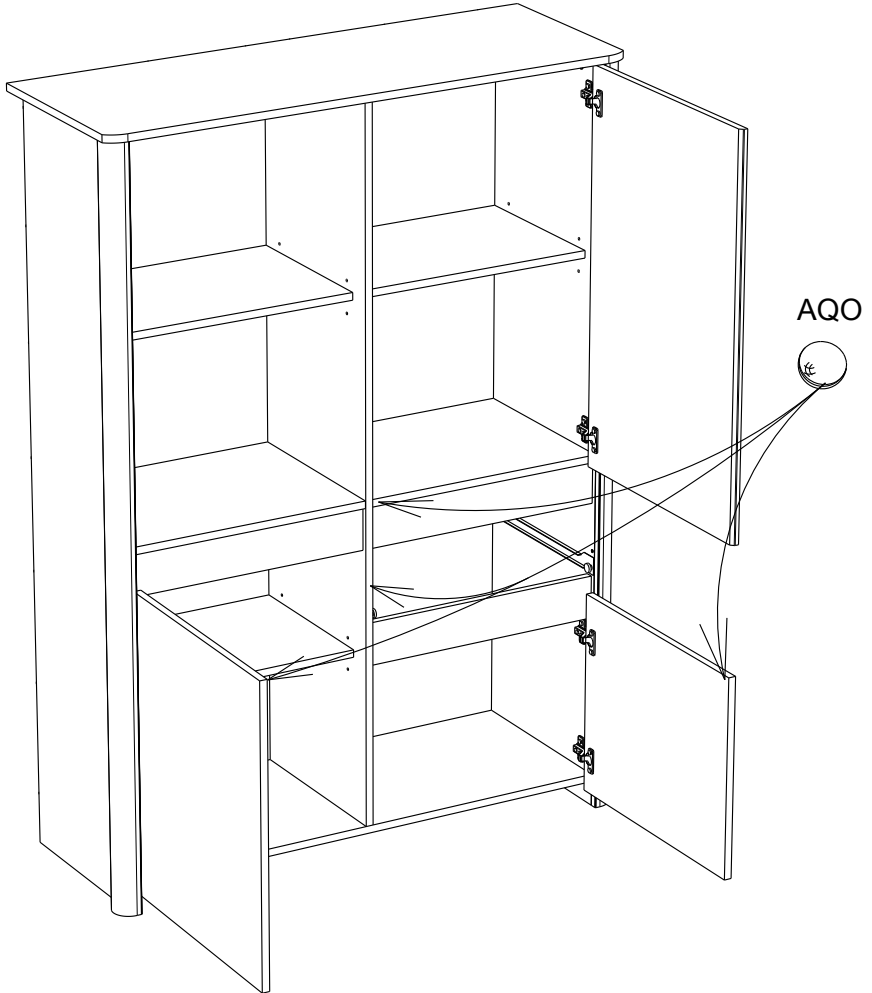

32

