

RO

### Deconectați aparatul de la sursa de alimentare înainte de a-l curăța.

Îndepărtați cu grijă praful. Folosiți o cârpă moale și curată, umedă, cu apă și săpun. Ștergeți cu o cârpă curată. Nu utilizați niciodată produse abrazive (pudră, vată de oțel) sau solvenți.

### Pentru șezuturi cu înveliș textil:

Materialul scaunului are o tendință naturală de a se scămoșa. Acesta nu este un defect dacă:

- Scămoșarea poate fi îndepărtată ușor sau se reduce în timp.
- Cantitatea scamelor nu afectează semnificativ estetica produsului.

### Material textil acoperit cu PU:

Materialul textil acoperit cu PU este prin natura sa sensibil la sebum și transpirație: curățarea frecventă a zonelor expuse trebuie efectuată folosind un produs non-acid, cum ar fi săpunul de Marsilia.

### Pentru toate șezuturile:

Un șezut își va schimba în mod natural forma și aspectul pe măsură ce căptușeala se lasă sau se deplasează în timp. Pentru a prelungi forma produsului și a distribui uniform uzura, se recomandă insistent:

- Întoarceți pernele în mod regulat, dacă este posibil.
  - Neteziți suprafața șezuturilor imediat după o utilizare prelungită și masați pernele pentru a le restabili umflarea.
- Un șezut relax clasic poate fi așezat lângă un perete. Cu toate acestea, este necesar să se asigure o distanță de cel puțin 0,3 m față de acesta pentru a putea utiliza corect produsul.

فصل الجهاز عن مصدر الطاقة قبل تنظيفه.  
أزل الغبار بعناية. استخدم قطعة قماش ناعمة ونظيفة مبللة بالماء والصابون. جفف بقطعة قماش نظيفة.  
لا تستخدم أبدًا أي مواد كاشطة (بودرة، صوف فولاذي) أو منيبات.

### للمقاعد المغطاة بقماش:

- يميل نسيج مقعدك إلى التكتل بشكل طبيعي. لا يُعد هذا عيبًا إذا:
- سهولة إزالة التكتل أو بهتانته بمرور الوقت،
- عدم تأثير عدد التكتل بشكل كبير على جمالية المنتج.

### النسيج المغطى بطبقة من البولي يوريثان:

النسيج المغطى بطبقة من البولي يوريثان حساس بطبيعته للدهون والعرق: يجب تنظيف المناطق المكشوفة بشكل متكرر باستخدام منتج غير حمضي مثل صابون مارسيليا.

### لجميع المقاعد:

- يتغير شكل المقعد ومظهره بشكل طبيعي مع ترحل الحشوة أو تغيرها بمرور الوقت. لإطالة عمر منتجك وتوزيع التآكل بالتساوي، يُنصح بشدة بما يلي:
- قلب الوسائد بانتظام، إن أمكن.
- تنعيم سطح المقاعد فورًا بعد الاستخدام المطول وتديل الوسائد لاستعادة انتفاخها.
- يمكن وضع مقعد الاسترخاء الكلاسيكي على الحائط. مع ذلك، من الضروري ترك مسافة لا تقل عن 0.3 متر بينه وبين الكرسي لفرده بشكل صحيح.

Ce produs fait l'objet d'une consigne de tri.



<https://quefairedemesdechets.fr>



A104250

(FR) NOTICE DE MONTAGE (EN) ASSEMBLY INSTRUCTIONS

(RO) INSTRUȚIUNI DE MONTAJ نصائح التنظيف

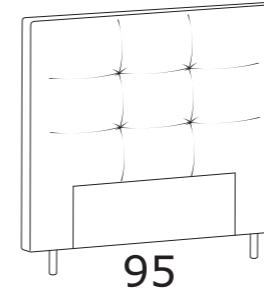
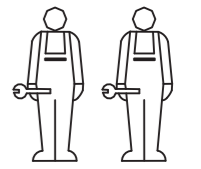

95

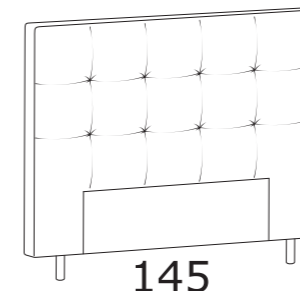

145

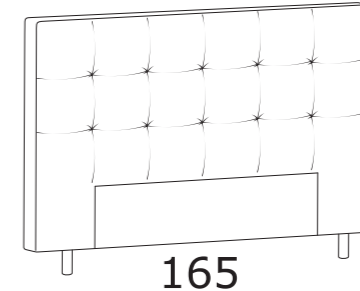

165

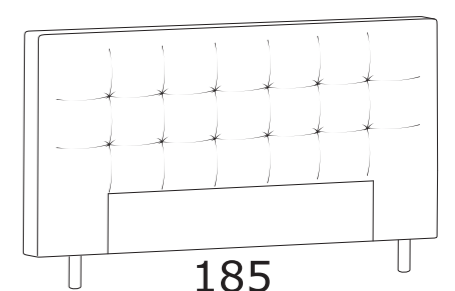

185



## La nature vous remercie !

En achetant votre canapé en kit, vous contribuez à préserver l'environnement.

## Nature Thanks you !

By buying your sofa knock-down packed, you're helping to protect the environment.

### Réduction des émissions de carbone

Nos canapés en kit **compact**s nécessitent moins d'espace lors du **transport** ce qui **réduit** les émissions de carbone.



### Carbon emission reduction

Our **compact** knock-down sofas require less space during **transportation**, thus **reducing** carbon emissions.

### Facilité de réparation et de remplacement

Au besoin, vous pouvez uniquement remplacer la partie endommagée, **prolongeant** ainsi la **durée de vie** du canapé.



### Ease of repair and replacement

When needed, you can simply replace the damaged part, thereby **extending the lifespan** of the sofa.

### Longévité et Adaptabilité

La conception en kit permet la **réversibilité** afin de **s'adapter** à vos différents **besoins** dans le temps.

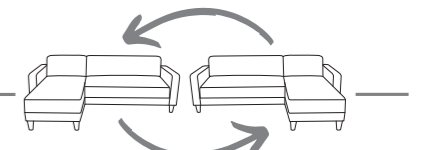

### Longevity and adaptability

The modular design allows for **reversibility**, **adapting** to your various **needs** over time.

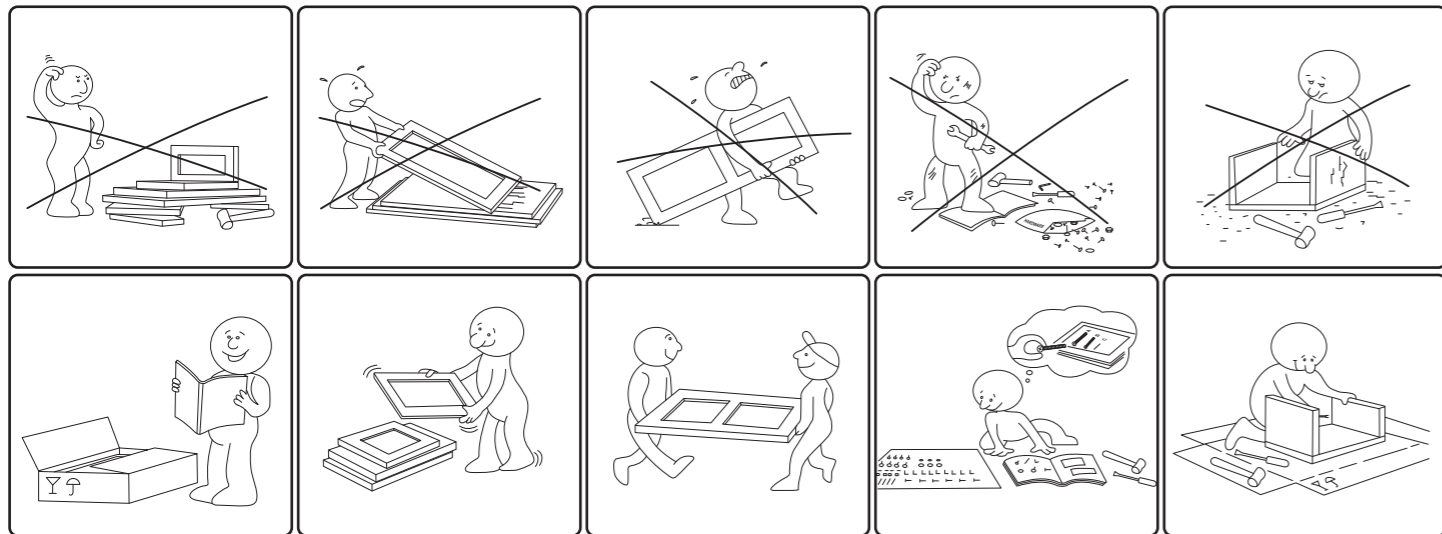

**FR IMPORTANT — Veuillez lire attentivement — Conservez ce document pour référence ultérieure.**

- À monter soi-même.
- Ne convient pas aux enfants de moins de 6 (six) ans.
- Ne pas assembler ni utiliser le meuble si des pièces sont cassées, endommagées ou manquantes. Utiliser uniquement des pièces de rechange approuvées par le fabricant.
- Vérifier la présence et l'état de toutes les fixations et pièces avant de commencer l'assemblage.
- Utiliser uniquement les outils fournis ou recommandés.
- Serrer correctement les fixations avec les outils fournis ou recommandés.
- Un assemblage, un serrage ou une manipulation incorrects peuvent fragiliser les assemblages et/ou les pièces.
- Tenir les jeunes enfants éloignés pendant l'assemblage. Présence de petites pièces susceptibles d'être avalées.
- Utilisez votre produit sur une surface plane et stable.
- Ne déplacez pas les meubles chargés.
- Tous les éléments de fixation doivent être correctement serrés et vérifiés régulièrement, puis resserrés si nécessaire.

**AVERTISSEMENT : Ce siège n'est pas destiné aux personnes souffrant d'un handicap physique et nécessitant une position assise prolongée et fréquente.**

**AVERTISSEMENT : Ce produit est destiné à un usage récréatif ou de détente. Ce produit n'est pas conforme aux normes en vigueur relatives aux dispositifs médicaux.**

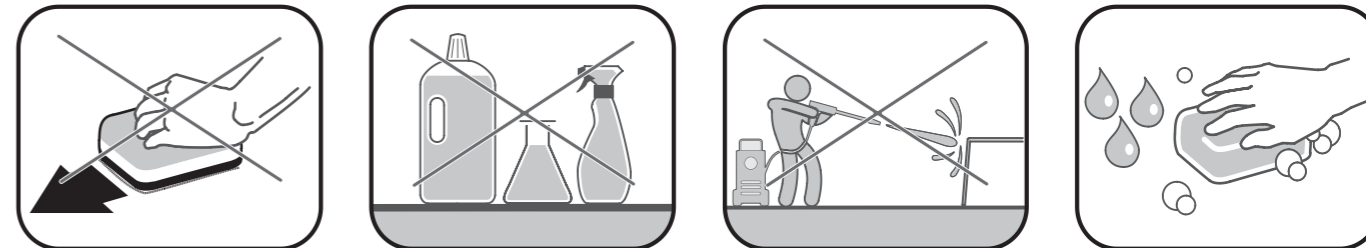

**FR**

**Débranchez l'appareil avant de le nettoyer.**

Enlevez soigneusement la poussière. Utilisez un chiffon doux, propre et humide avec de l'eau savonneuse. Essuyez avec un chiffon propre.

N'utilisez jamais de produit abrasif (poudre, laine d'acier) ni de solvants.

**Pour les sièges recouverts de tissu :**

Le tissu de votre siège a naturellement tendance à boulocher. Ceci n'est pas un défaut si :

- Les bouloches s'enlèvent facilement ou s'estompent avec le temps.
- Leur nombre n'altère pas significativement l'esthétique du produit.

**Textile enduit de PU :**

Le textile enduit de PU est naturellement sensible au sébum et à la transpiration : nettoyez fréquemment les zones exposées avec un produit non acide, comme du savon de Marseille.

**Pour tous les sièges :**

Un siège se déforme et change d'aspect naturellement avec le temps, le rembourrage s'affaissant ou se déplaçant. Afin de préserver la forme de votre produit et d'uniformiser l'usure, il est fortement recommandé :

- de retourner régulièrement les coussins, si possible;
- de lisser la surface des sièges immédiatement après une utilisation prolongée et de masser les coussins pour leur redonner leur volume.

Le siège relax classique peut être placé contre un mur. Toutefois, il est nécessaire de maintenir une distance minimale de 0,3 m avec celui-ci afin de pouvoir l'utiliser correctement.

**EN**

**Disconnect the appliance from the power source before cleaning it.**

Carrefully remove the dust. Use a soft and clean damp cloth with soapy water. Wipe dry with a clean cloth.

Never use an abrasive product (powder, steel wool) or solvents.

**For seat with textile covering:**

Your seat fabric will have a natural tendency to pill. This is not a defect if:

- Pilling can easily be removed or fade over time.
- The number of pills does not significantly affect the aesthetics of your product.

**PU coated textile:**

The PU coated textile is by nature sensitive to sebum and sweat: frequent cleaning of the exposed areas is to be carried out using a non-acid product such as Marseille soap.

**For all seats:**

A seat will naturally change shape and appearance as the padding sags or shifts over time. In order to prolong the shape of your product and evenly distribute wear, it is strongly recommended:

- Turn the cushions over regularly, if possible.
- To smooth the surface of the seats immediately after prolonged use and to massage the cushions to restore their swelling.

Classic relax seat can be placed against a wall. Nevertheless, it is necessary to provide at least 0.3 m distance with it in order to be able to deploy your seat correctly.

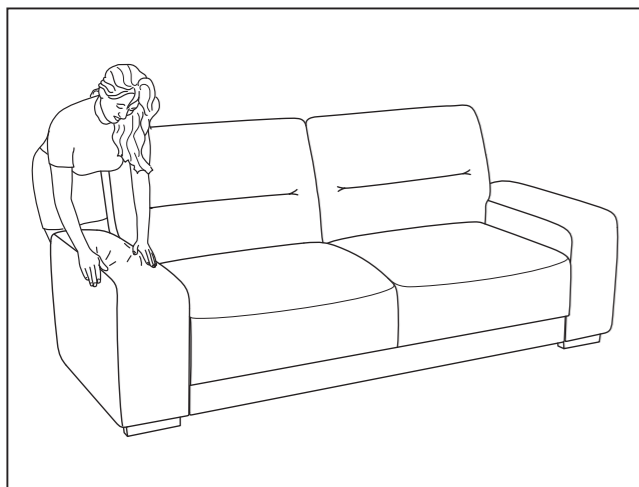
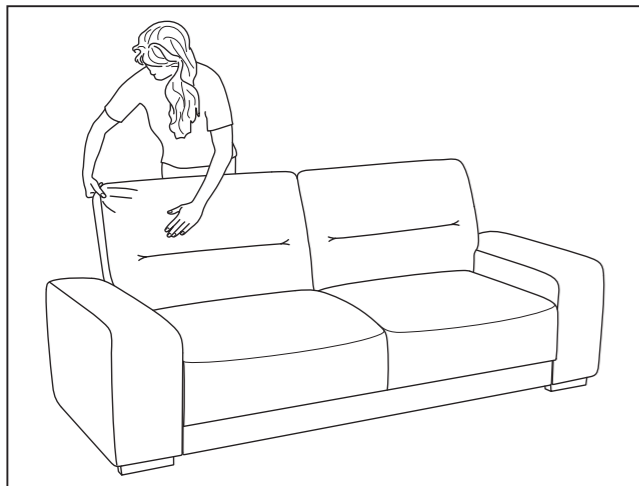
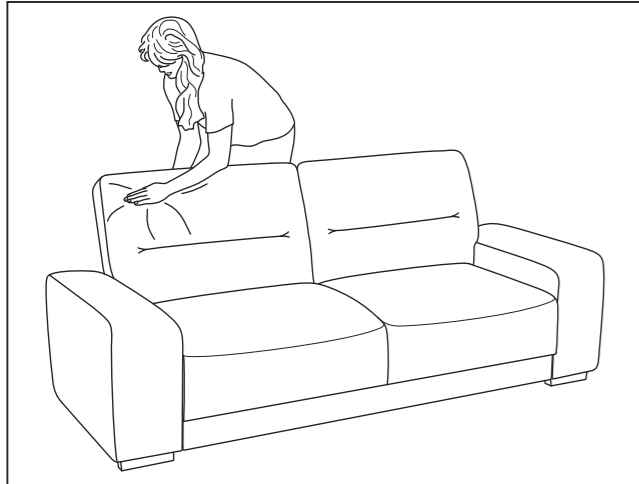
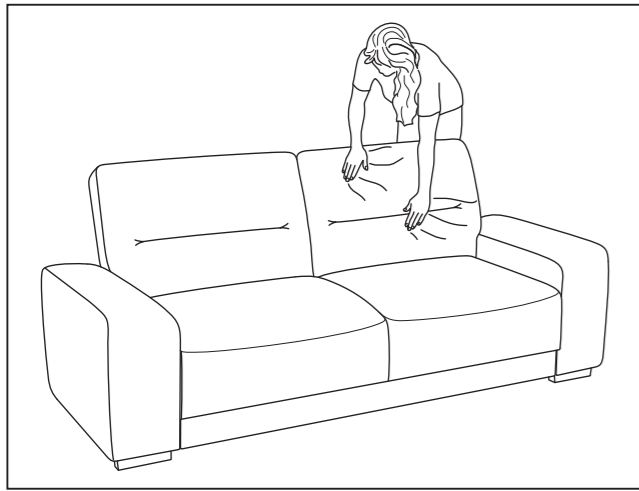

**FR** Cher client,  
En raison du transport et de son emballage optimisé, votre nouveau canapé peut présenter quelques plis disgracieux.  
Afin d'y remédier, n'hésitez pas à lisser, tapoter et «masser» la housse, comme indiqué dans les illustrations.  
Cela redonnera au canapé son aspect originel et attrayant.  
Nous souhaitons que votre nouveau canapé vous offre entière satisfaction.  
Votre équipe de création

**EN** Dear customers,  
As a result of transport and use, your new sofa is somewhat "stressed" and this is noticed on her. Because of this:  
\*Smooth, knock and shake all the upholstery as appropriate, as shown in the illustrations.  
\*This leaves the sofa looking beautiful, prim and attractive.  
We want your new sofa to offer you full satisfaction.  
Your creative department team

**RO** Stimați clienți,  
În urma transportului solicitant și a utilizării de zi cu zi, noua dvs. canapea este puțin "stresată" și acest lucru se observă la ea.  
De aceea:  
Neteziți, bătați și scuturați puțin toate tapițeriile în mod corespunzător, după cum se indică în ilustrații.  
Acest lucru conferă canapelei frumusețe, eleganță și atractivitate.  
Vă dorim ca noua dvs. canapea să vă ofere satisfacții depline.  
Departamentul dvs. de creație produse

عزيزي الزبون:

نظرًا للنقل وتعبئته المحسنة، قد يُظهر كنبتك الجديدة بعض التجاعيد غير الجميلة. للقضاء عليها، لا تتردد في ترك الغطاء يتدلى وتدليكه، كما هو موضح في الصور.  
سيعيد ذلك إلى الكنبية مظهرها الأصلي الجذاب.  
نتمنى لك أن تكون راضيا على كنبتك الجديدة.  
فريق التصميم

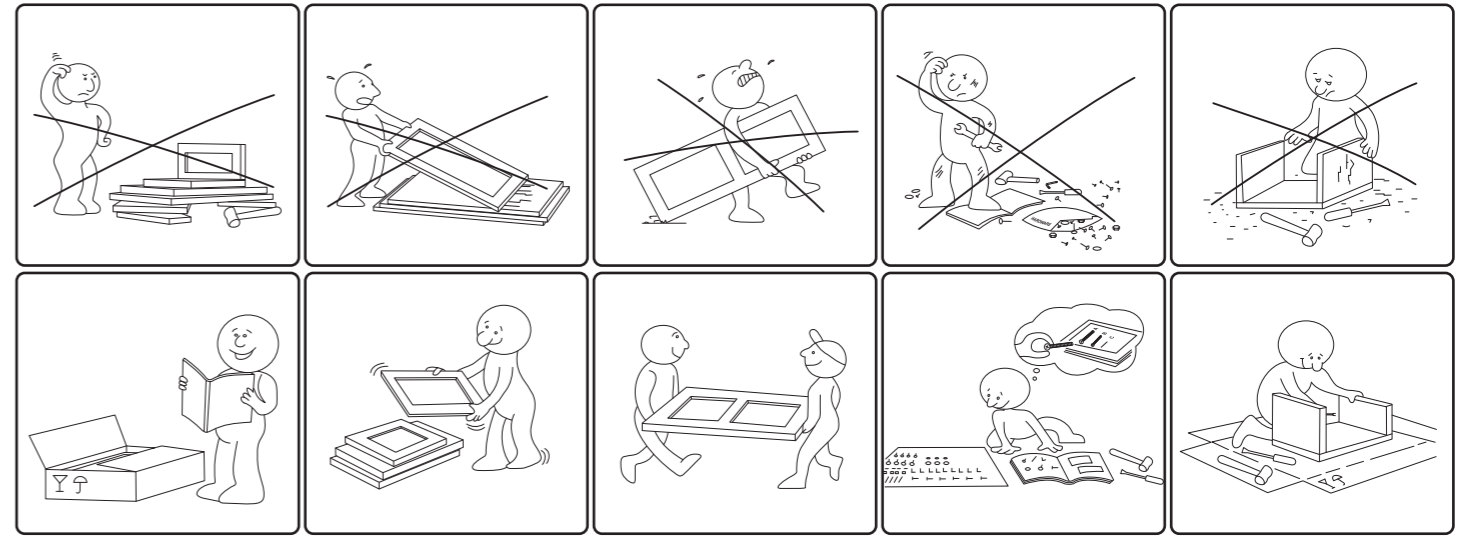

**EN IMPORTANT — Please read carefully — Keep for future reference.**

- To assemble by yourself.
- Not suitable for children under 6 (six) years old.
- Do not assemble or use the furniture if any parts are broken, damaged, or missing, and only use spare parts approved by the manufacturer.
- Check the presence and state of all hardware and parts before beginning assembly.
- Use only the tools provided or recommended.
- Tighten fasteners properly with the tools provided or recommended.
- Improper assembly, wedging, or handling can weaken the assemblies and/or parts.
- Keep young children away during assembly. Presence of Small parts liable to be swallowed.
- Use your product on stabilized, level ground.
- Do not move loaded furniture.
- All joining devices should be properly tightened and regularly checked, and re-tightened, if necessary.

**WARNING: Do not use this seat for people suffering of a physical handicap and needing a seated continue and frequent position.**

**WARNING: This product shall be used in a frame of leisure or relaxation. This product does not comply with the norms in force for medical material.**

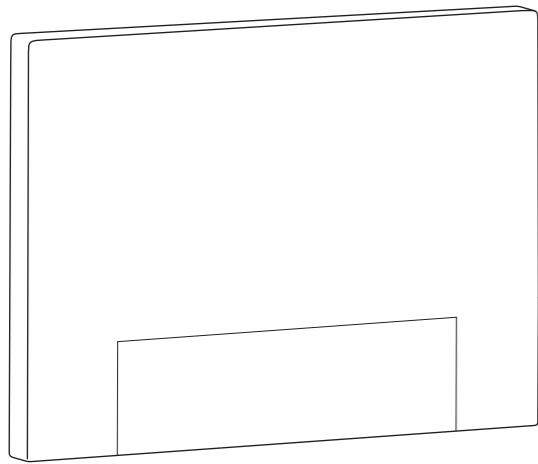

### SN

- FR** Le numéro de série des colis
- EN** The serial number of the parcels

SN

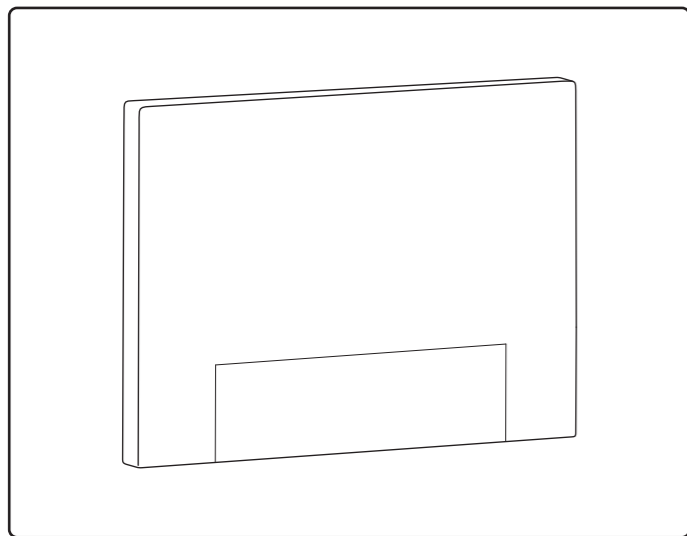
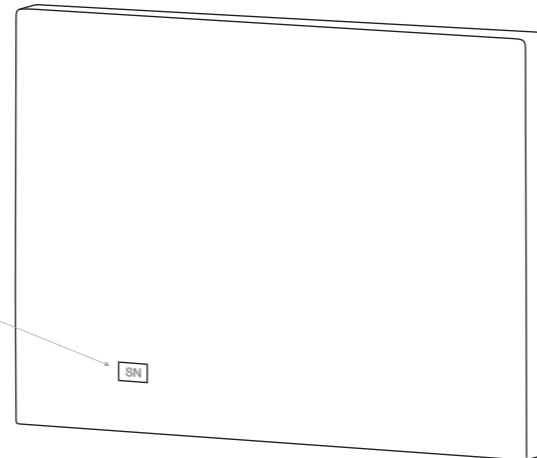

C1/1

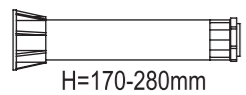
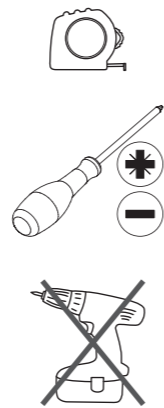

H=170-280mm

Ax2

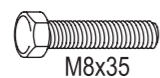

M8x35

Bx2



Cx4



4x20

Dx4

5

## FIXATION

Une fois fixée, votre tête de lit doit reposer au sol.

Once fixed, your headboard must sit on the ground.

Erstmal fixieren, (Ihr) Kopfteil auf den Boden legen.

Una volta fissato, vostra testata deve essere sul terreno.

Una vez fijado, su cabecera debe sentarse en el suelo.

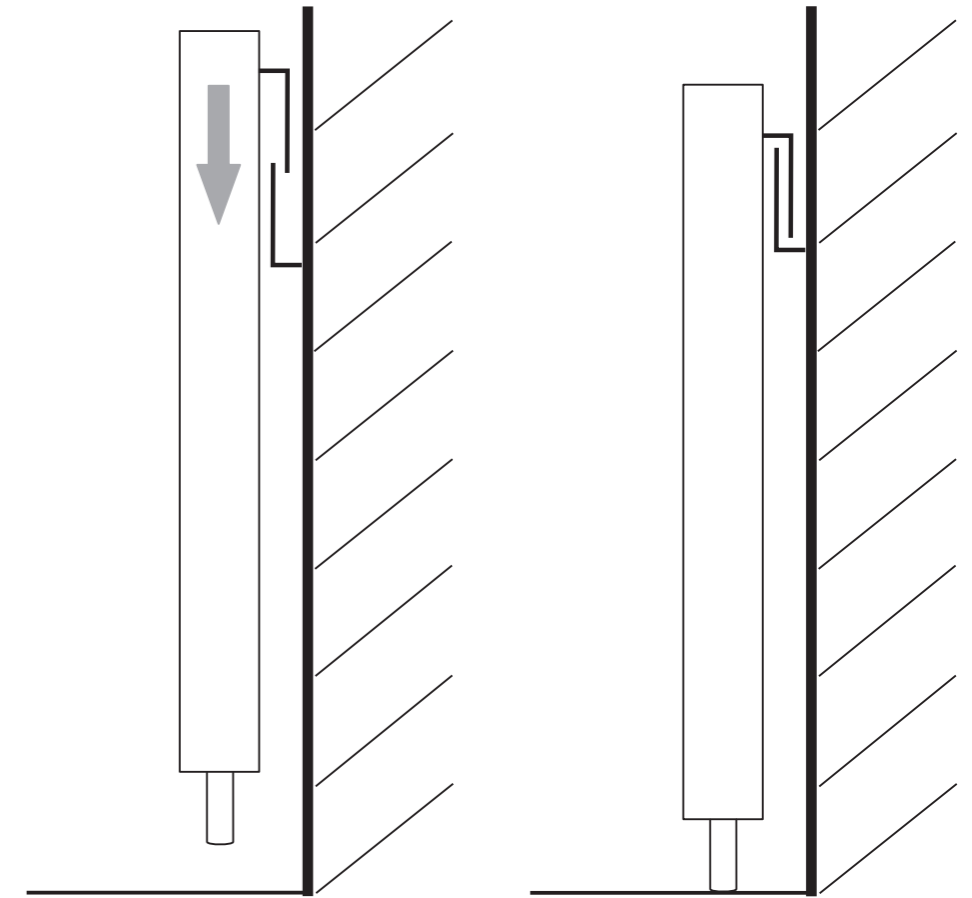

**!** À usage domestique / For domestic use / Pentru uz casnic / للاستعمال المنزلي فقط

**FR** Les meubles contenant des panneaux à base de bois peuvent émettre des substances polluantes dans l'air intérieur. Il est donc recommandé, après l'installation du meuble, d'aérer fréquemment la pièce pendant au moins quatre semaines.

**EN** Furniture containing wood-based panels can emit pollutants into the indoor air. It is therefore recommended, after the installation of the furniture, to ventilate the room frequently for at least four weeks.

**RO** Mobilierul care conține panouri pe bază de lemn poate emite substanțe poluante în aerul din interior. Prin urmare, după instalarea mobilei, este recomandată aerisirea frecventă a camerei timp de cel puțin patru săptămâni.

قد تصدر الأثاث التي تحتوي على ألواح خشبية مواد ملوثة للهواء الداخلي. لذلك، يُنصح بتهوية الغرفة بانتظام بعد تركيب الأثاث لمدة لا تقل عن أربعة أسابيع

4

### systeme de fixation sur le mur

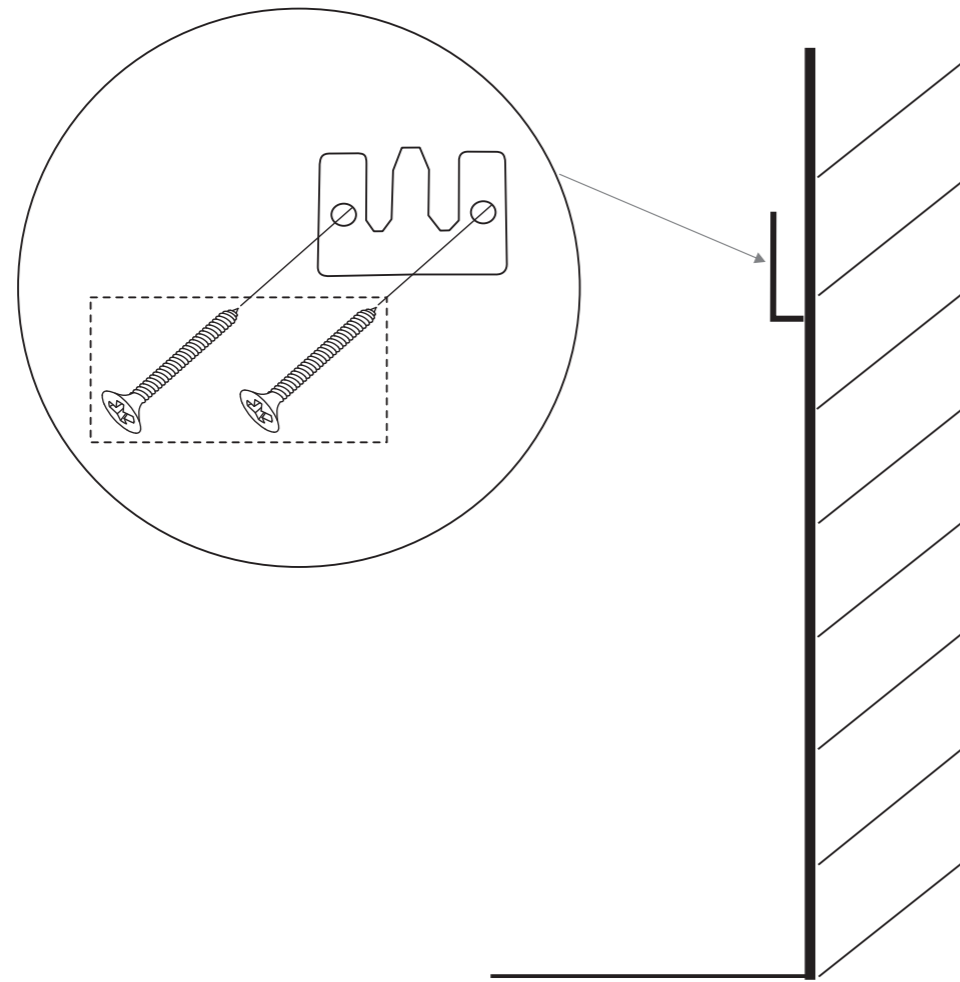

Choisir des vis adaptées à votre type de mur

Select screws suitable for your type of wall

Sortieren Sie die passenden Schrauben für Ihren Wandtyp heraus

Selezionare le viti adatto per il tipo di parete

Seleccione los tornillos adecuados para el tipo de pared



1

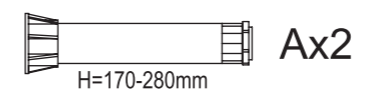
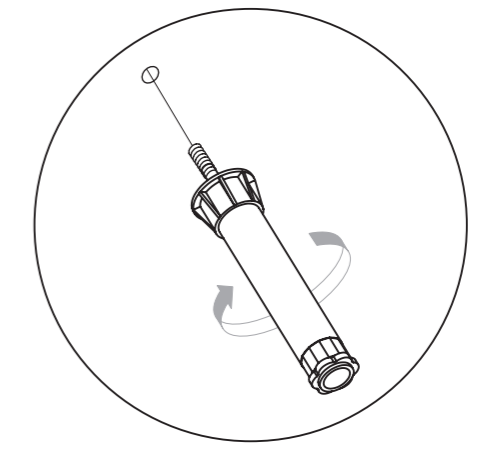
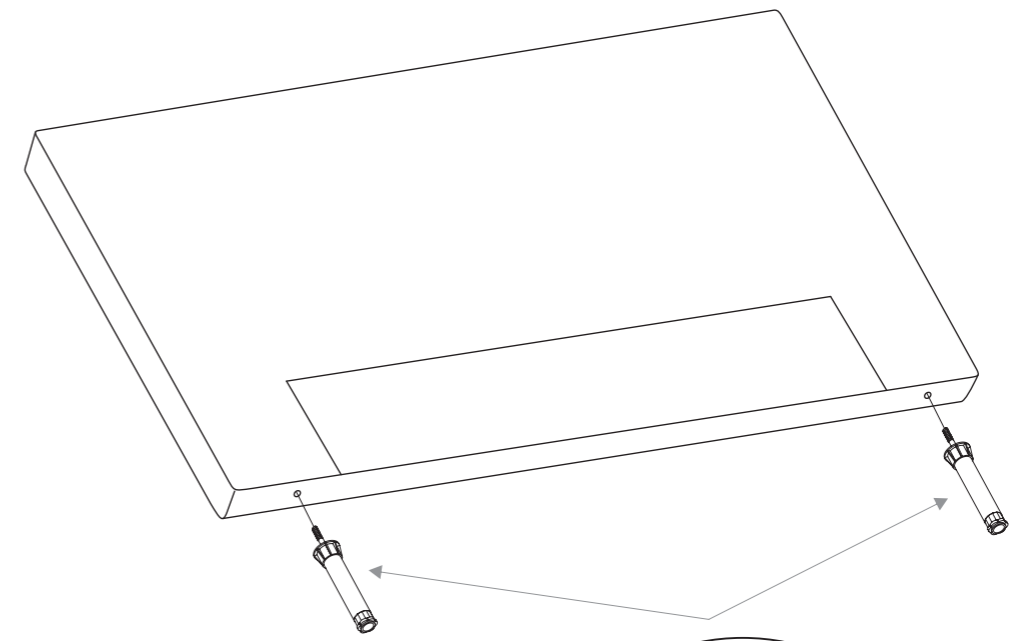
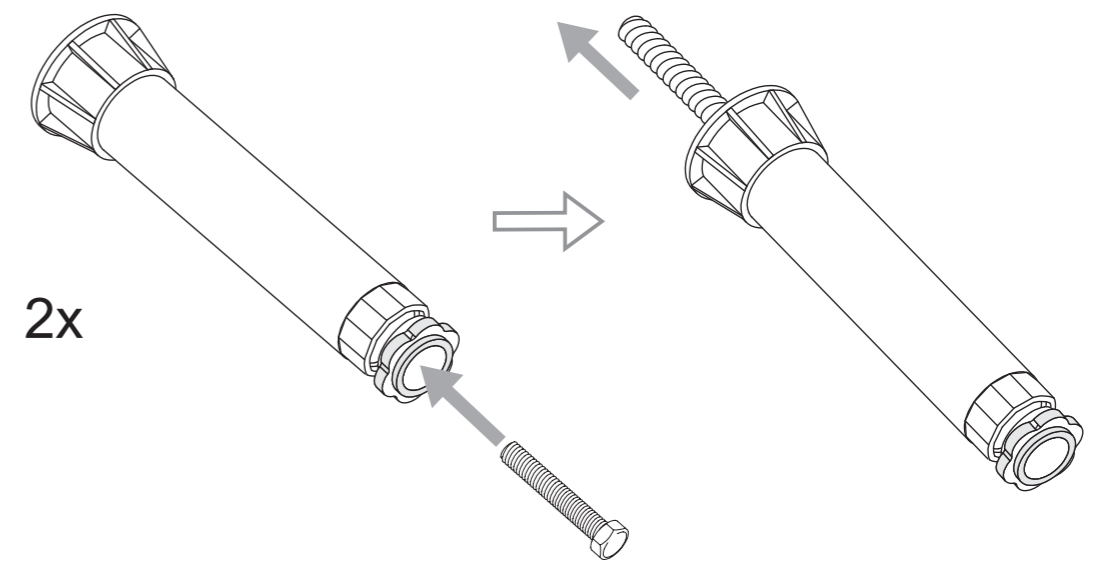

2

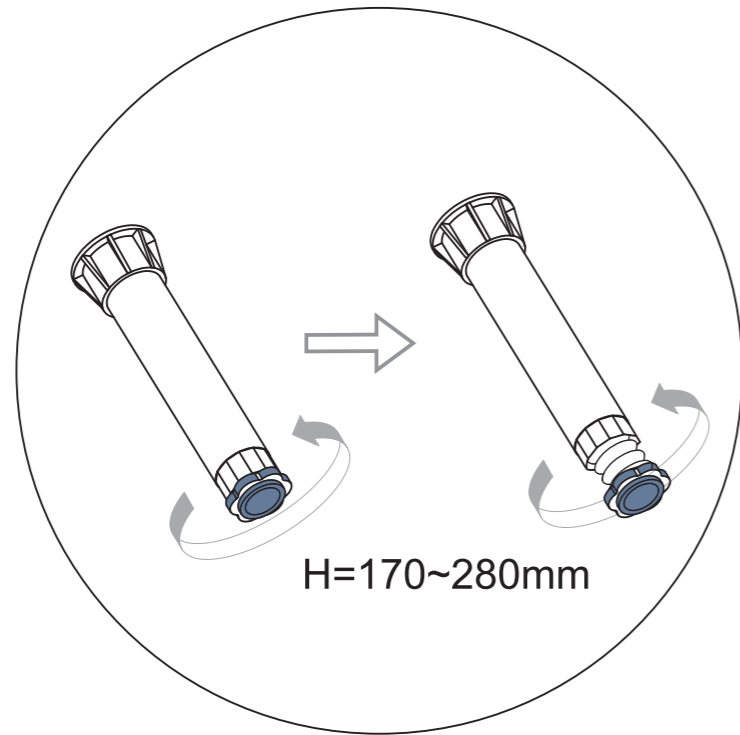
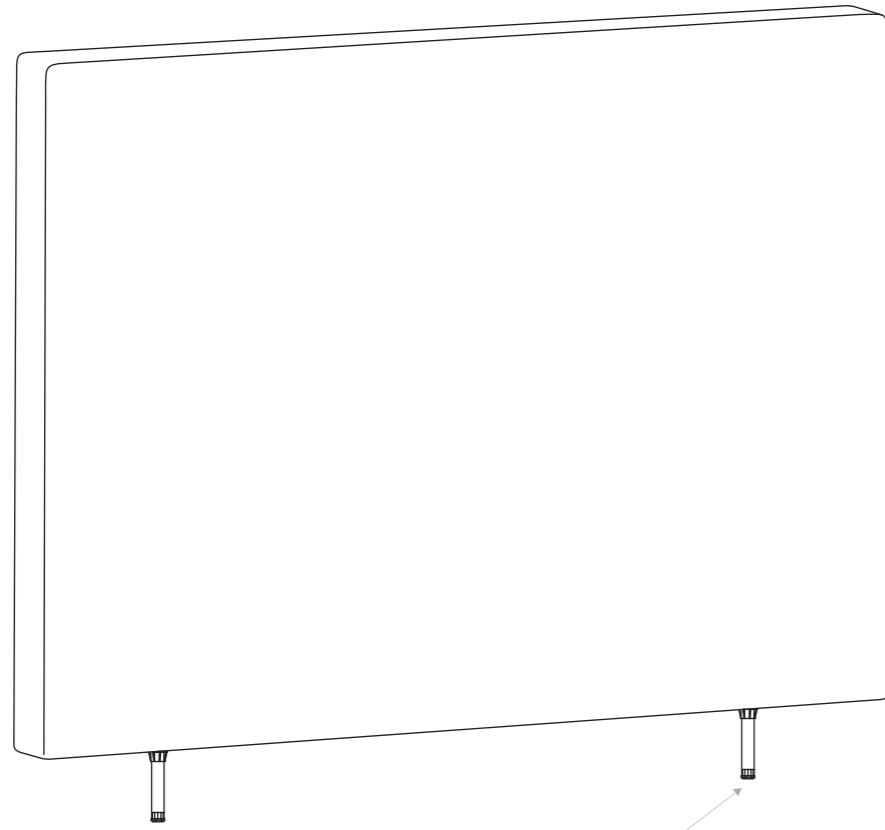

3

