

## PRODUCT INFORMATION / INFORMATIONS PRODUIT

Cher Client, afin de vous assurer la meilleure traçabilité de votre produit nous vous recommandons de reporter le numéro de série présent sur chaque colis sur ce document et de le conserver

Dear Customer, in order to ensure the best traceability of your product we recommend that you enter the serial number on each parcel on this document and keep it

Le numéro de série des colis / The serial number of the parcels

Colis 1 / Parcel 1	Colis 2 / Parcel 2

Colis 3 / Parcel 3	Colis 4 / Parcel 4

Colis 5 / Parcel 5	Colis 6 / Parcel 6

Pour exemple / For example

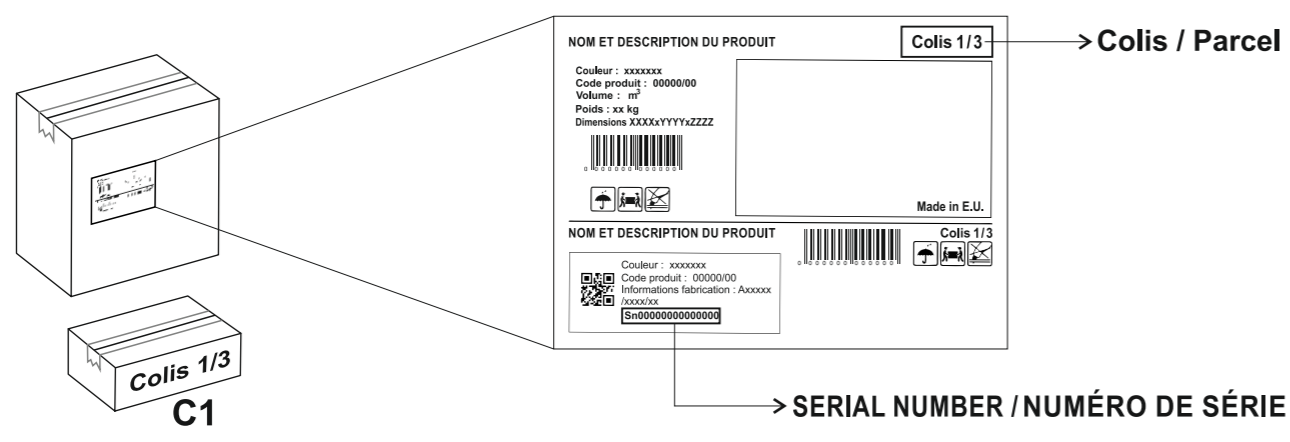

# PGS

A92770

NOTICE DE MONTAGE • ASSEMBLY INSTRUCTIONS  
MONTAGEANLEITUNG • MONTERINGSVEJLEDNING  
MONTERINGENS-INSTRUKSJON BESKRIVELSE • ASENNUSOHJE  
INSTRUKCJA MONTAŻU • MONTERINGSANVISNING • INSTRUCIUNI  
DE MONTAJ • NÁVOD KE SLOŽENÍ • SZERELÉSI ÚTASÍTÁS • NÁVOD  
NA MONTÁŽ • INSTALLATIE INSTRUCTIES • NAVODILA ZA MONTAŽO  
UPUTE ZA MONTAŽU • УПУТСТВО ЗА ИНСТАЛАЦИЈУ

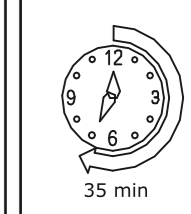
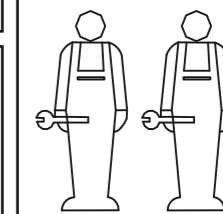

### FR: IMPORTANT!

Il est important que tout produit monté à l'aide de vis soit resserré 2 semaines après son montage, puis tous les 3 mois, afin de garantir sa stabilité durant tout son cycle de vie.

### EN: IMPORTANT!

It is important that any product which is assembled using any kind of screw is re-tightened 2 weeks after assembly, and once every 3 months - in order to assure stability through-out the lifespan of the product.

### DE: WICHTIG!

Alle Schrauben, die zur Montage verwendet wurden, müssen 2 Wochen nach dem Aufbau und danach alle 3 Monate nachgezogen werden. Dies gewährleistet die Stabilität und Lebensdauer des Produkts.

### DK: VIGTIG!

Det er vigtigt, at alle produkter, der samles med alle former for skruer, efterspændes to uger efter samling samt hver tredje måned for at sikre, at produktet er stabilt i hele dets levetid.

### NO: VIKTIG!

Det er viktig at alle produkter som monteres med skruer blir etterstrammet 2 uker etter montering, og hver 3. måned for å sikre stabiliteten gjennom hele produktets levetid.

### FI: TÄRKEÄÄ!

On tärkeää, että kaikki ruuvien avulla koottavat tuotteet kiristetään uudelleen 2 viikkoa kokoamisen jälkeen ja aina 3 kuukauden välein, jotta tuote pysyy vakaana koko käyttöikänsä ajan.

### ES: IMPORTANTE!

Es importante que cualquier producto que se ensambla con cualquier tipo de tornillos se vuelva a apretar 2 semanas después del ensamblaje y una vez cada 3 meses para garantizar la estabilidad durante toda la vida útil del producto.

### PL: WAŻNE!

Ważne jest, żeby każdy ze skręcanych produktów został ponownie dokręcony w ciągu 2 tygodni od montażu, a następnie sprawdzać co 3 miesiące czy śruby są dokręcone - w celu zapewnienia stabilności przez czas użytkowania produktu.

140x190 // 160x200

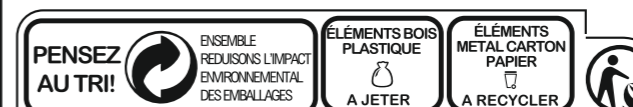
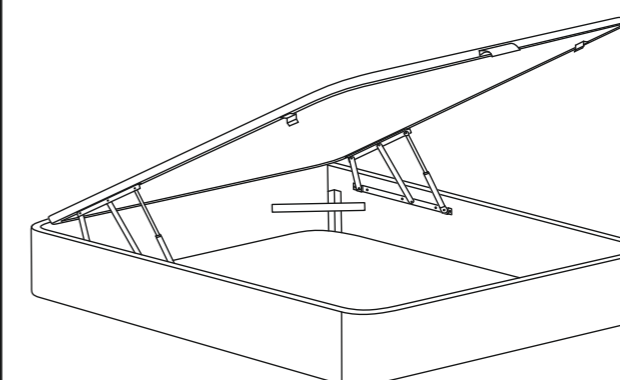
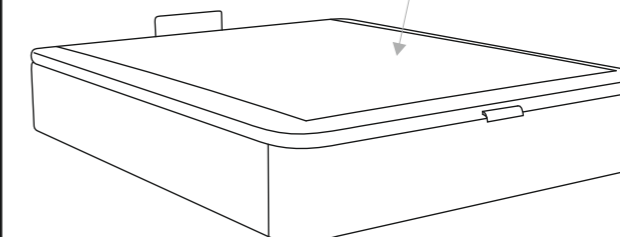
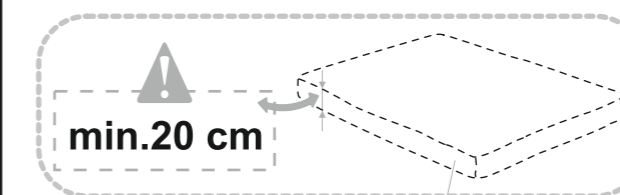

CONSIGNES POUVANT VARIER LOCALEMENT • WWW.CONSIGNESDETRE.FR

### SE: VIKTIGT!

För alla produkter som monteras med skruv är det viktigt att dessa efterdras två veckor efter monteringen och därefter en gång var tredje månad. Detta för att säkerställa att produkten håller sig stabil under hela sin livslängd.

### RO: IMPORTANT!

Este important ca șuruburile de orice tip, cu ajutorul căroră au fost montate produsele, să fie strânse din nou la 2 săptămâni după montare și, apoi, o dată la 3 luni, pentru a se asigura stabilitatea de-a lungul duratei de viață al produsului.

### PT: IMPORTANTE!

É importante que qualquer produto montado usando qualquer tipo de parafuso seja reapertado 2 semanas após a montagem e uma vez a cada 3 meses para garantir estabilidade durante toda a vida útil do produto

### CZ: DŮLEŽITÉ!

U každého výrobku, který se sestavuje pomocí jakýchkoli šroubků, je důležité dotáhnout šroubky 2 týdny po sestavení a potom každé 3 měsíce, aby byla zajištěna stabilita po celou dobu životnosti výrobku.

### HU: FONTOS!

Minden terméknél fontos, hogy bármilyen fajta csavarral is történik az összeszerelése, utána 2 héttel, majd 3 havonta rendszerességgel szükség van a csavarok utánhúzására. Ezzel a termék teljes élettartalmán keresztül biztosítható a stabilitása.

### SK: DÔLEŽITÉ!

Je dôležité, aby sa na akomkoľvek produkte, montovanom pomocou akýchkoľvek skrutiek, skrutky dotiahli po dvoch týždňoch od montáže, a jedenkrát v priebehu každých 3 mesiacov - tak sa zaručí stabilita počas celej životnosti produktu.

### NL: BELANGRIJK!

Het is belangrijk om elk product dat met om het even welk soort schroef wordt gemonteerd, twee weken na montage en om de drie maanden, opnieuw wordt vastgeschroefd, om de stabiliteit van het product tijdens de hele levensduur te verzekeren.

### SI: POMEMBNO!

Vsak izdelek, ki ga sestavite z uporabo kakršnihkoli vijakov morate 2 tedna po sestavitvi ponovno pregledati in vijake po potrebi priviti. To ponovite vsake 3 mesece, da bi zagotovili sta bilnost izdelka skozi njegovo celotno življenjsko dobo.

### HR: VAŽNO!

Važno je da se svi tipovi vijaka na bilo kojoj vrsti proizvoda koji se s pomoću njih sastavlja ponovno ču njih sastavlja ponovno pritegnu 2 tjedna nakon sastavljanja te jednom svaka 3 mjeseca - kako bi se zajamčila stabilnost tijekom životnog vijeka proizvoda.

### RS: VAŽNO!

Važno je da svaki proizvod koji je sklopljen korišćenjem bilo kakvih šrafova bude ponovo pričvršćen 2 nedelje nakon sklapanja i jednom svaka 3 meseca - kako bi se obezbedila stabilnost tokom celog veka trajanja proizvoda.



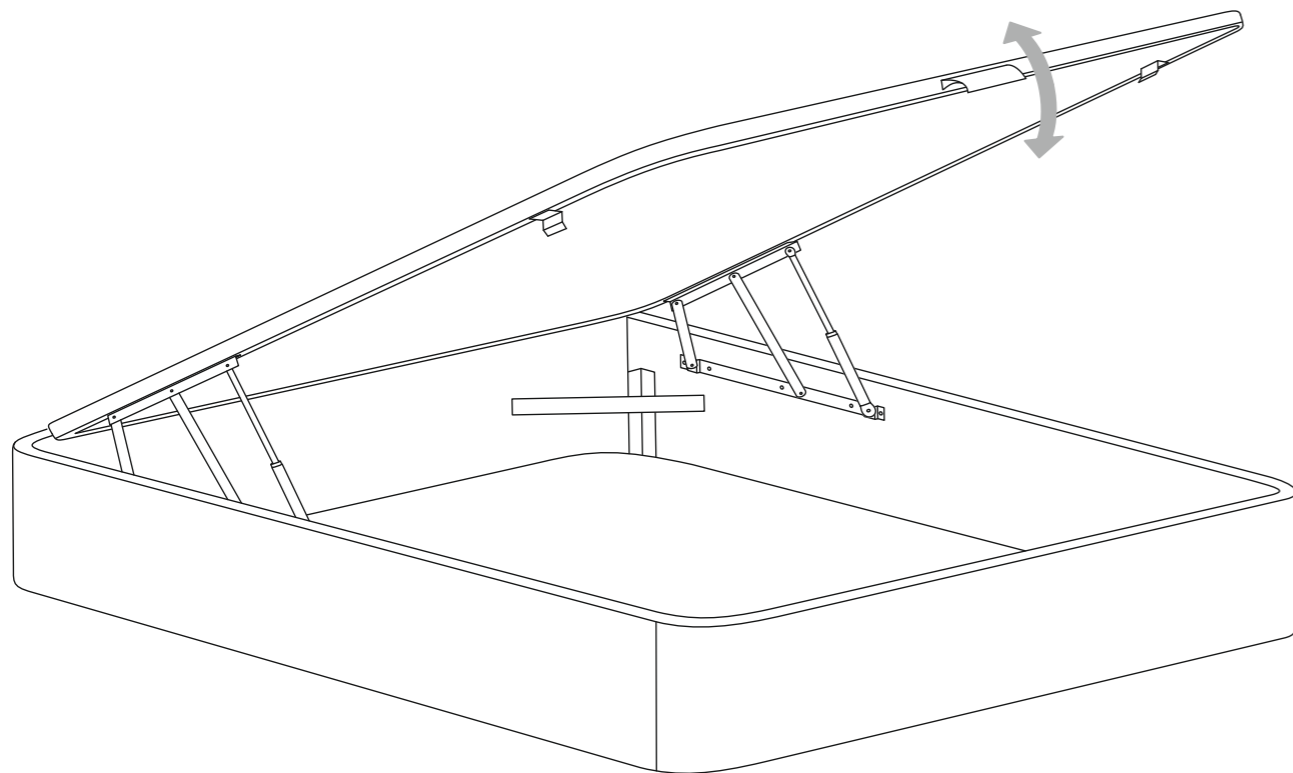
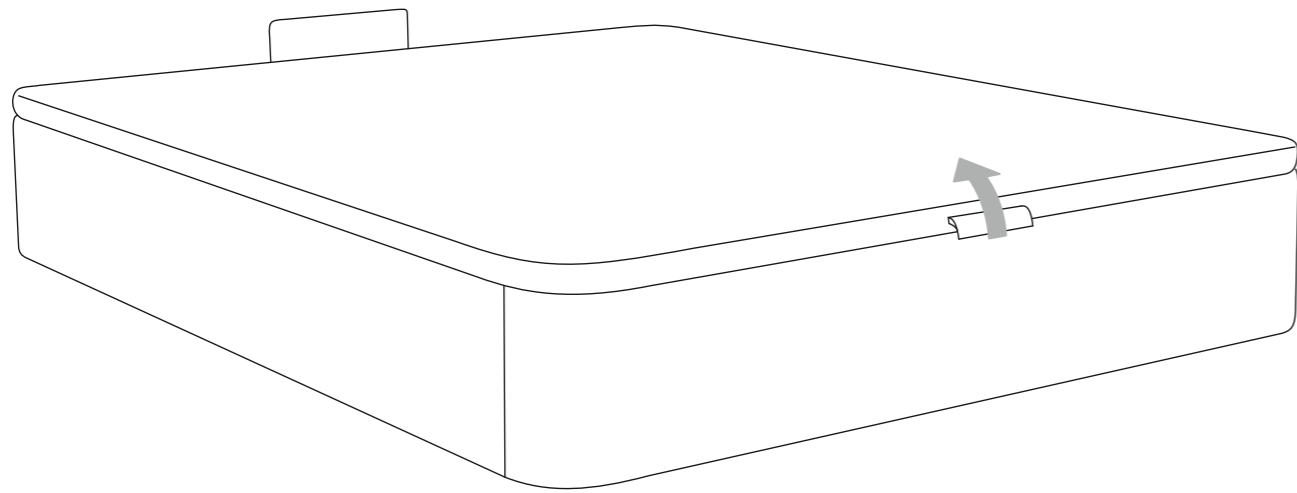

1

4x

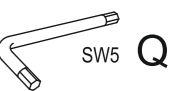
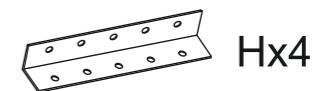
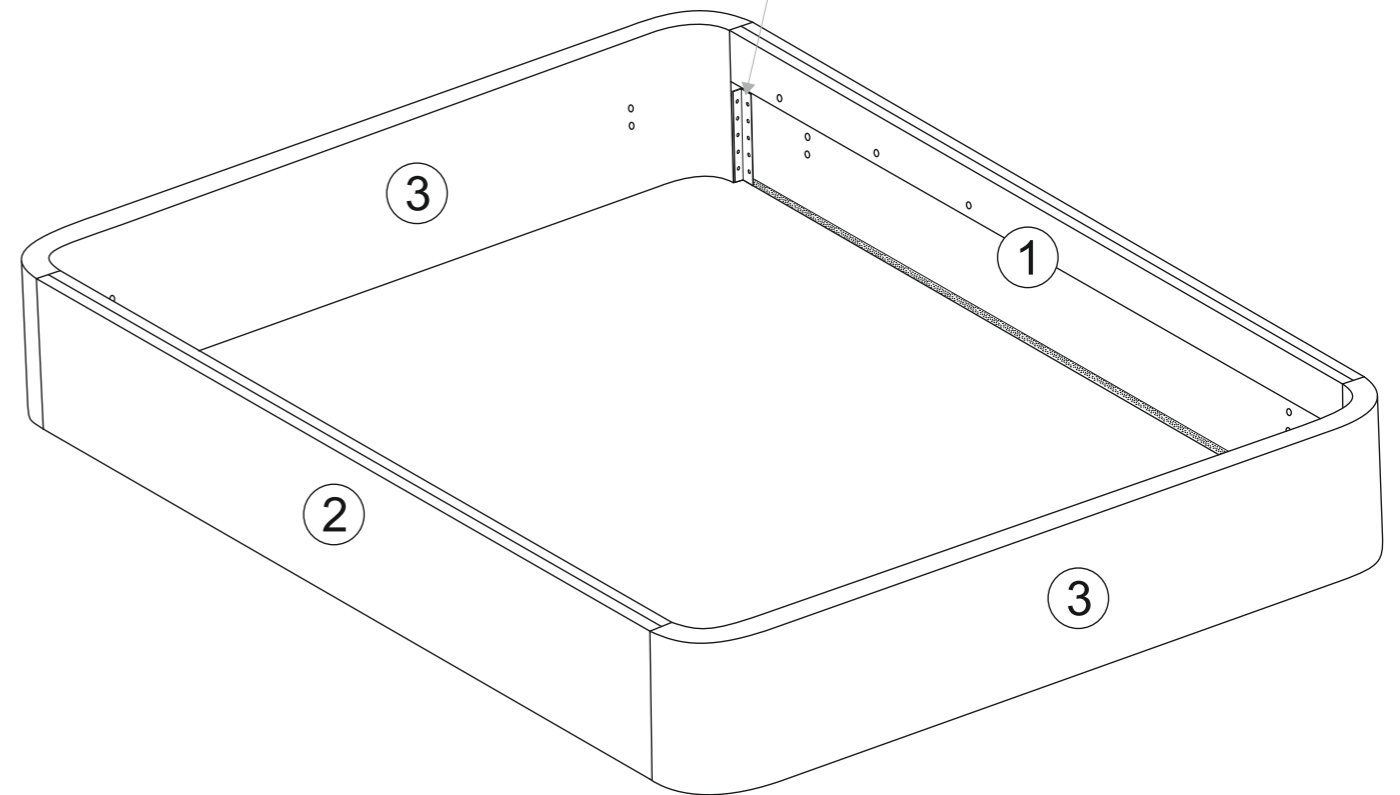
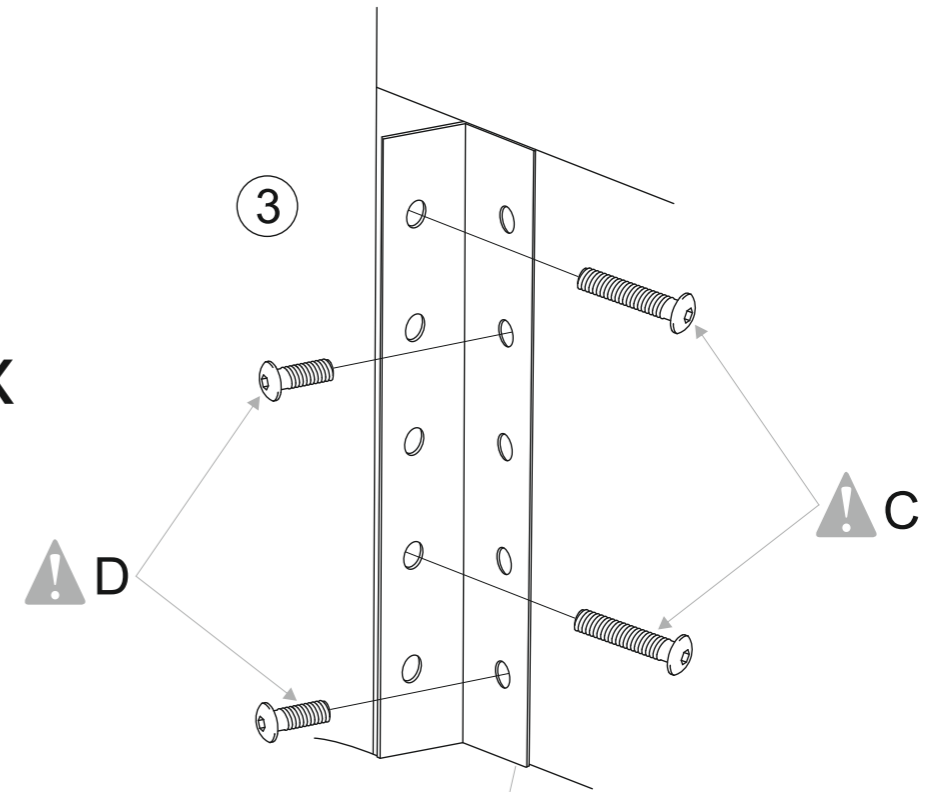

2

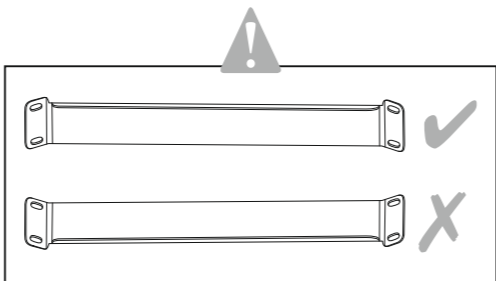

4x

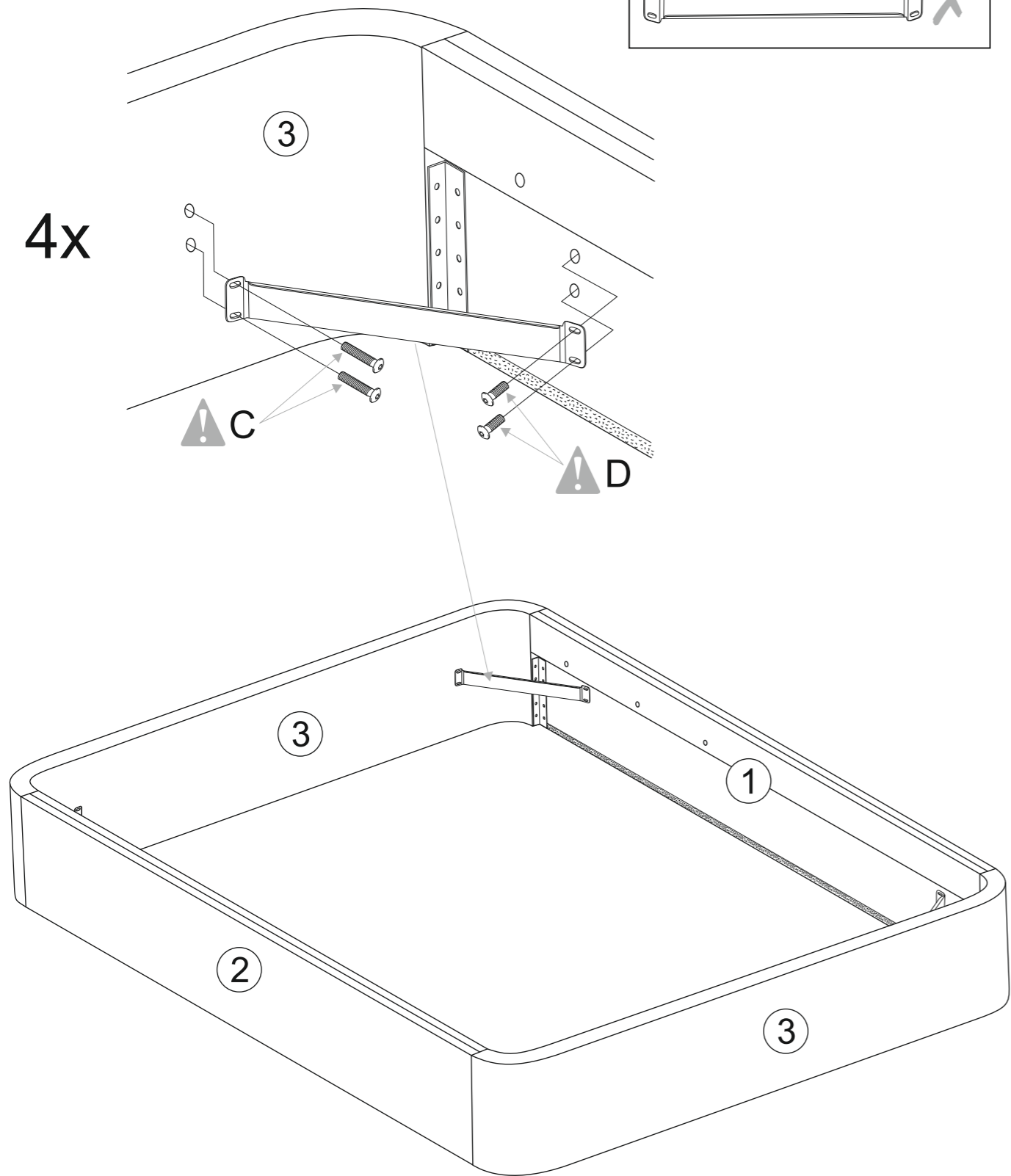

Cx8  
M6x30mm

Dx8  
M6x16mm

Ix4

SW5 Q

11

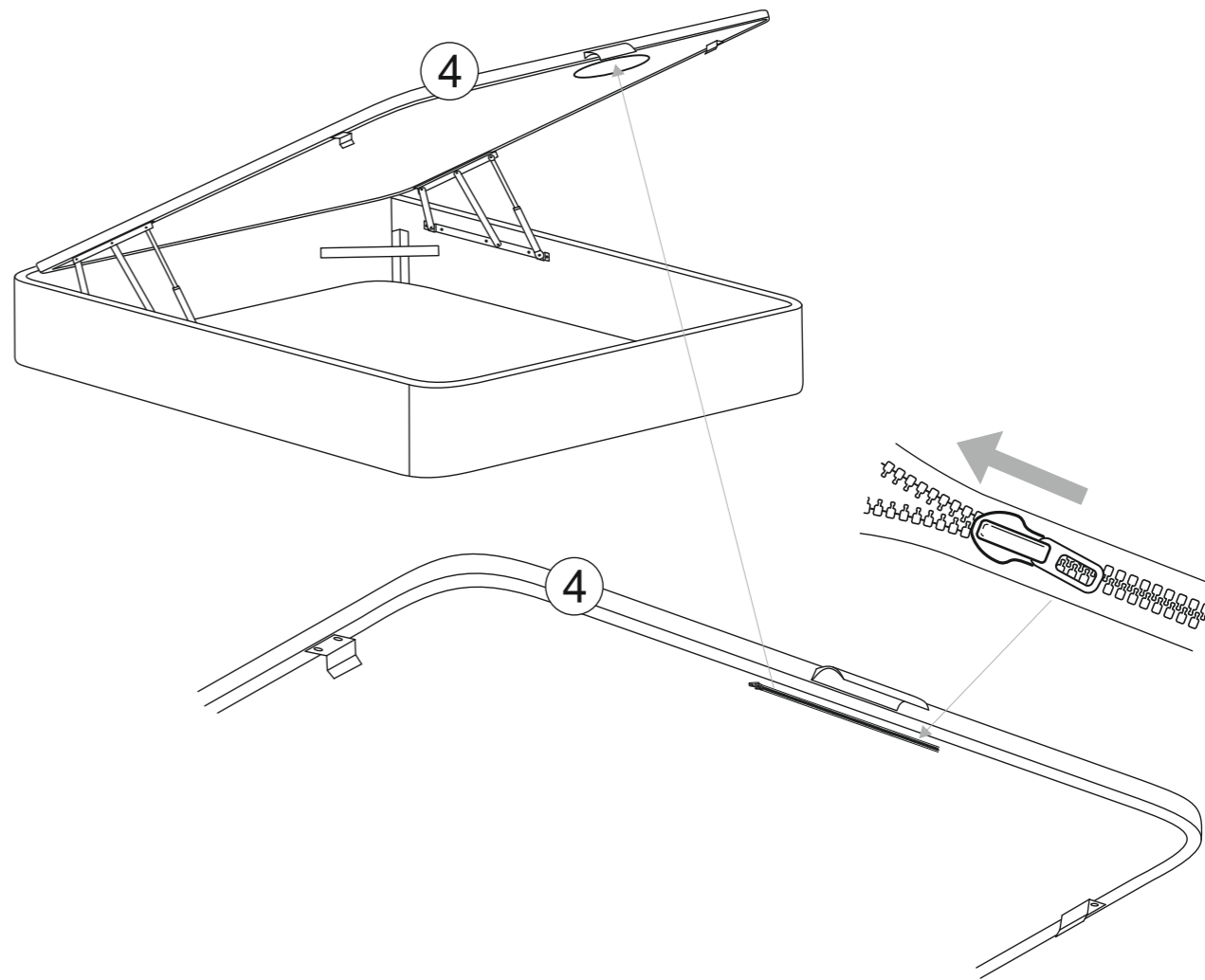

12

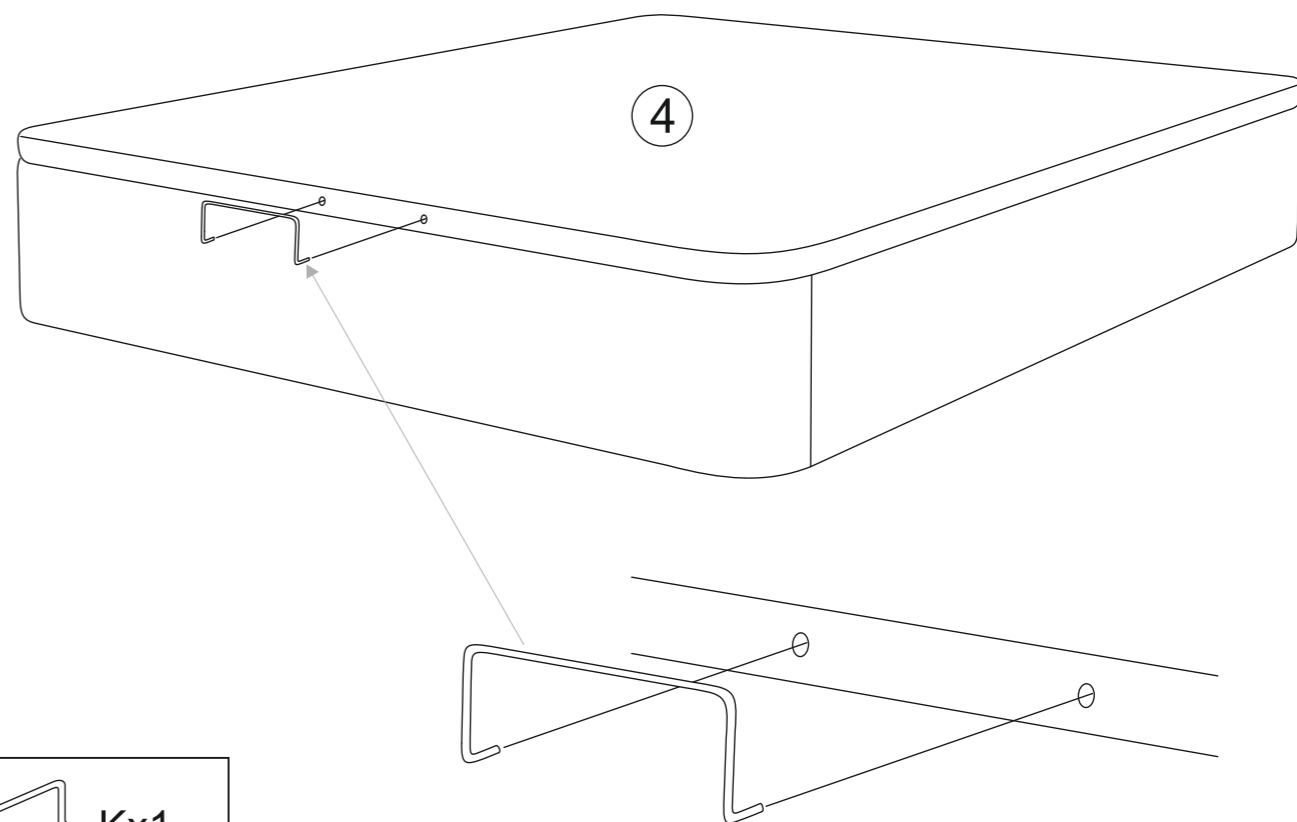

Kx1

10b

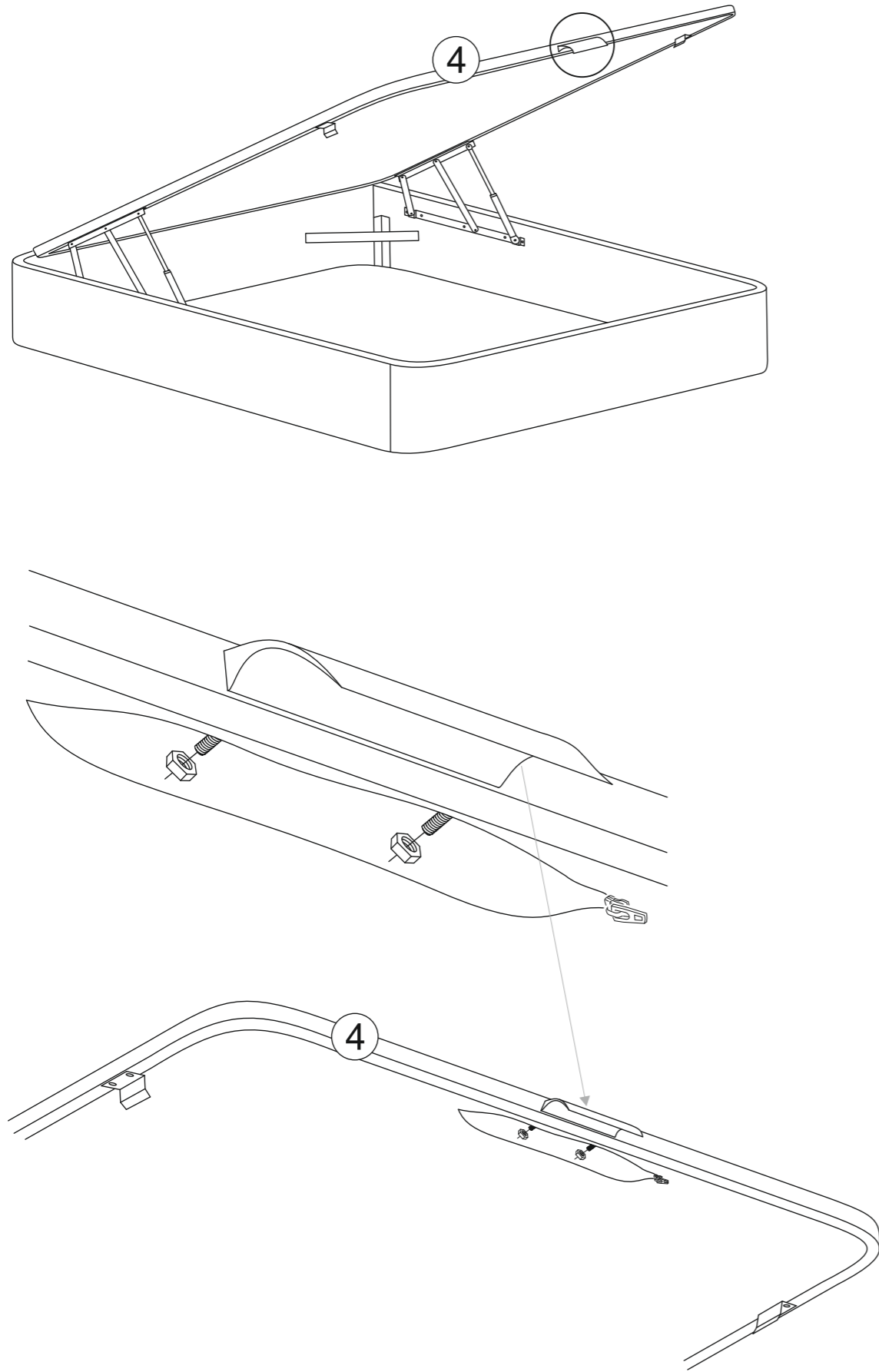

Gx2  
M4

7mm P

3a

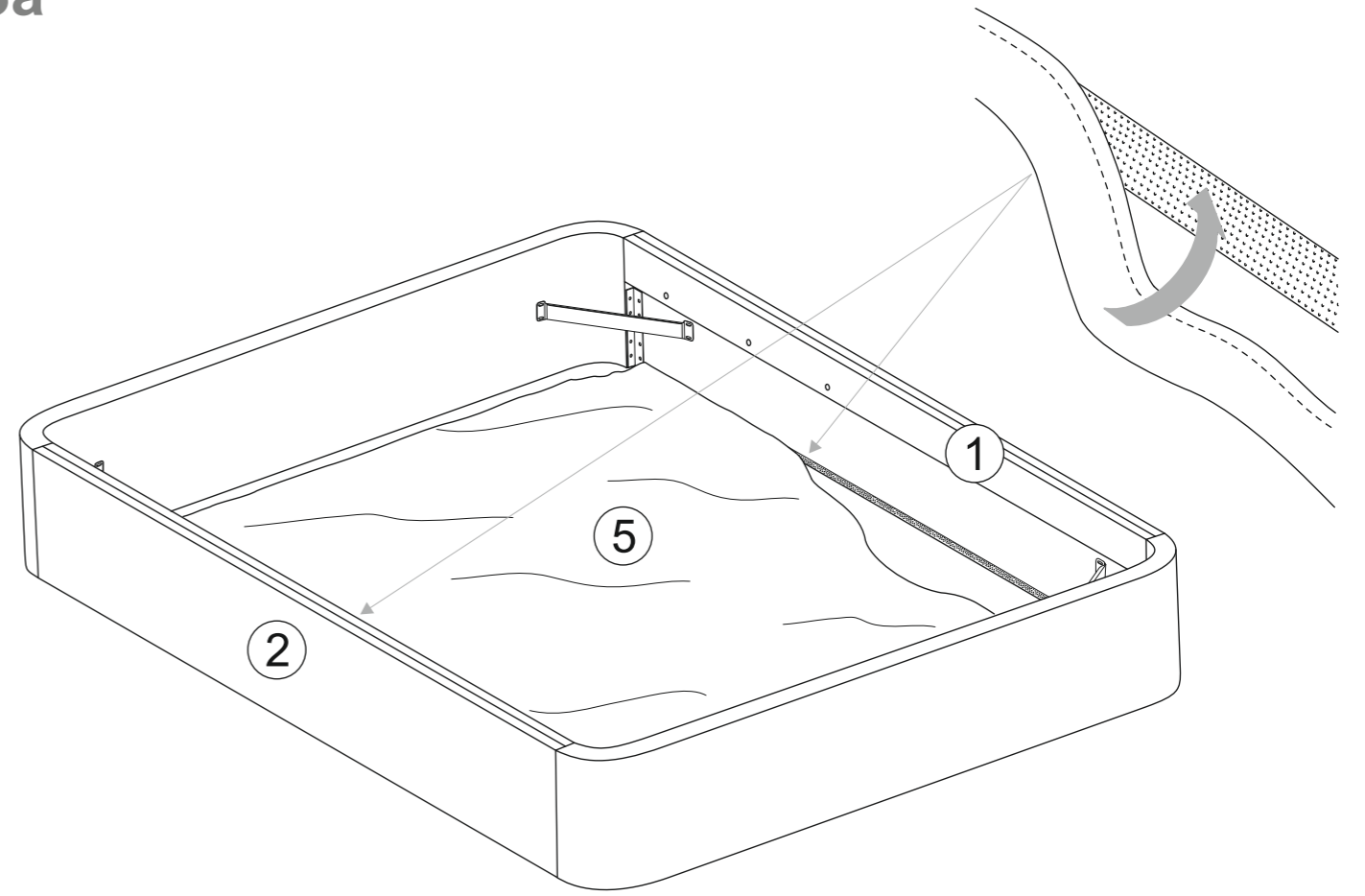

3b

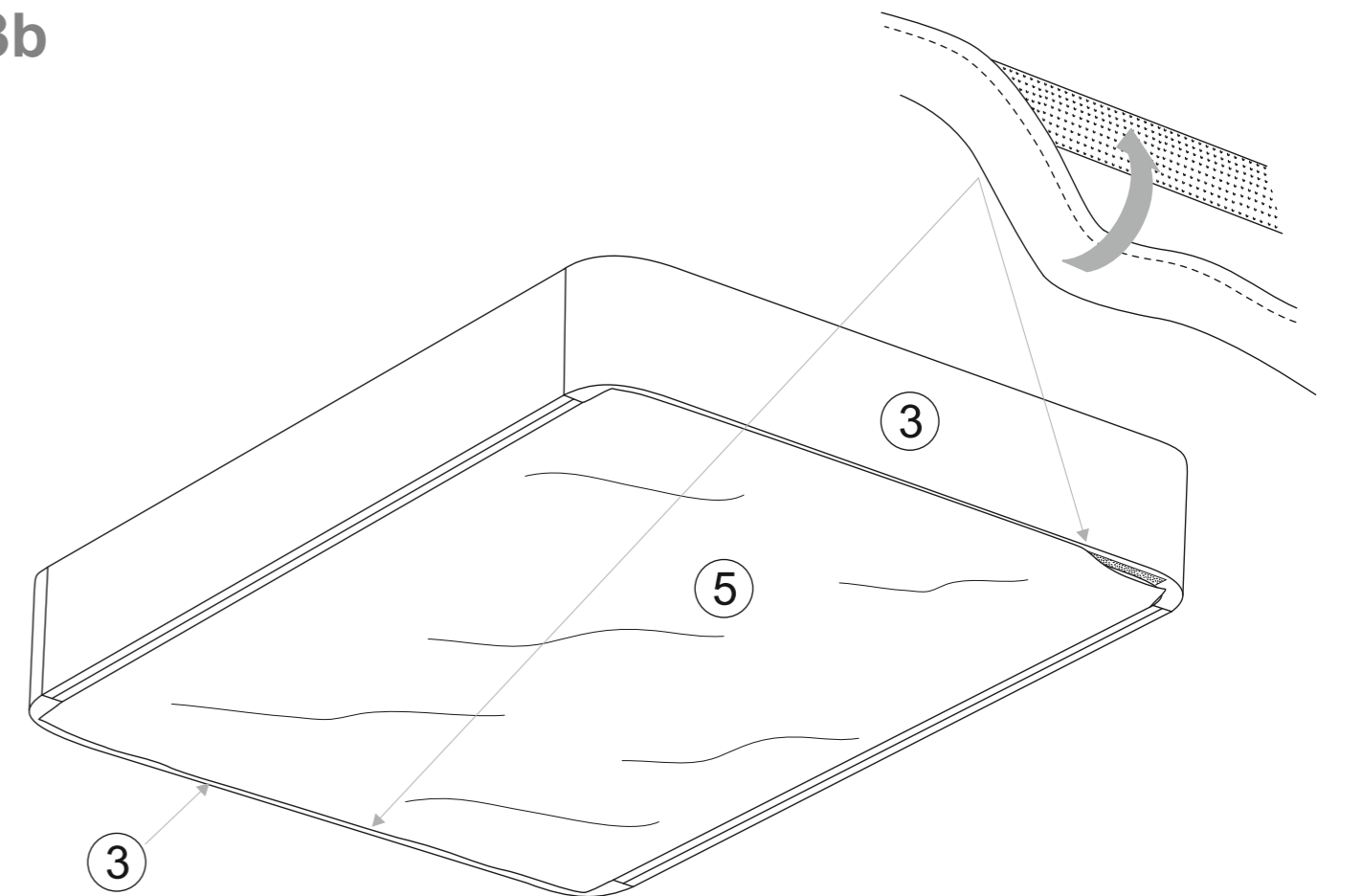

4

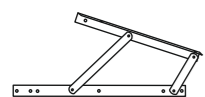
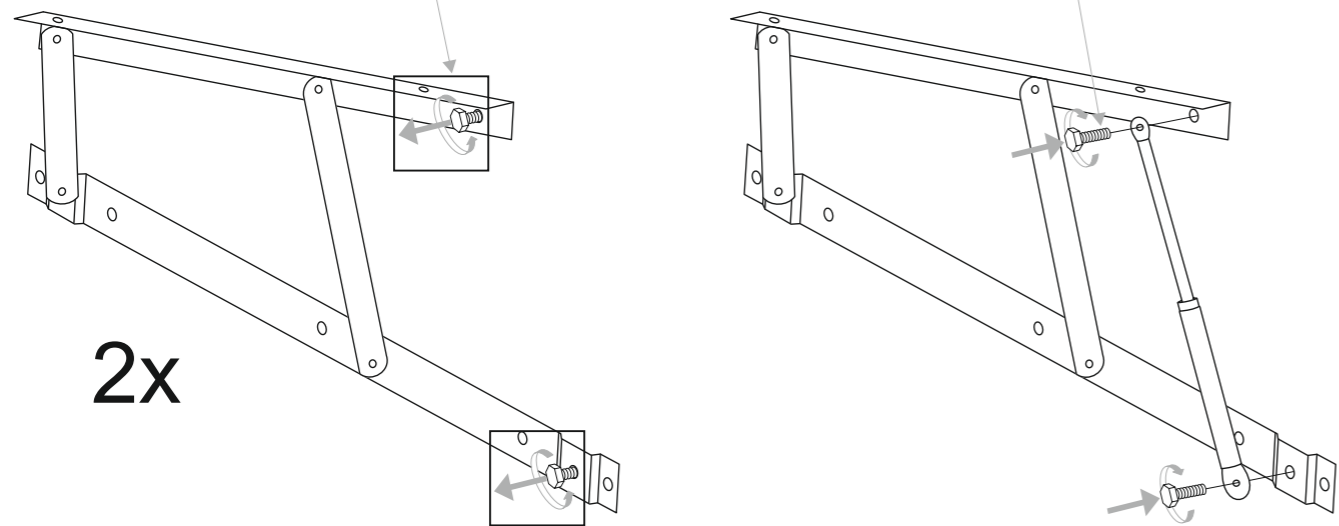
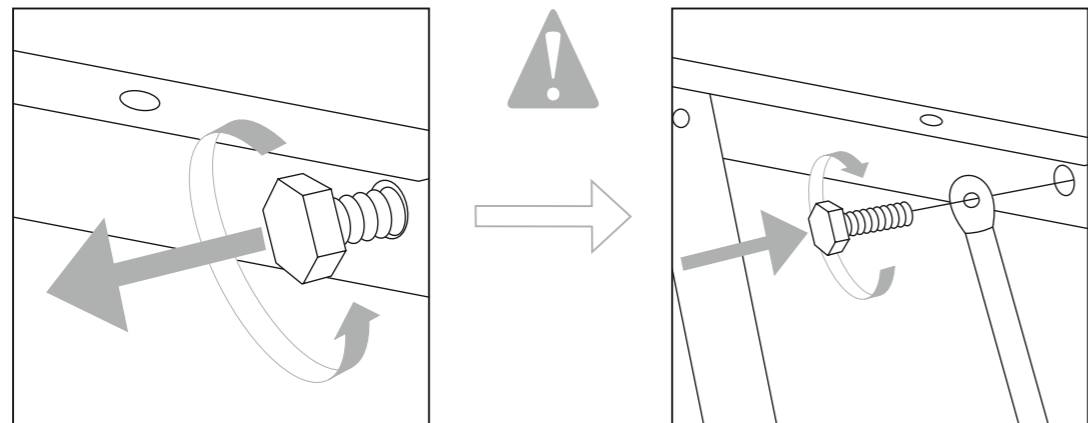

Mx1

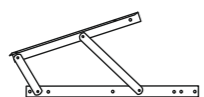

Nx1



Ox2

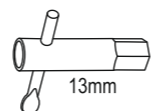

R

10a

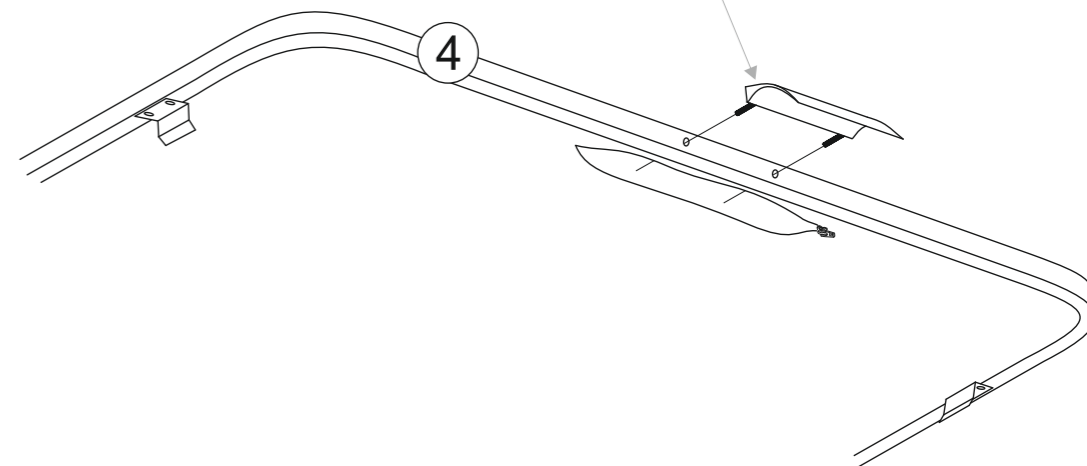
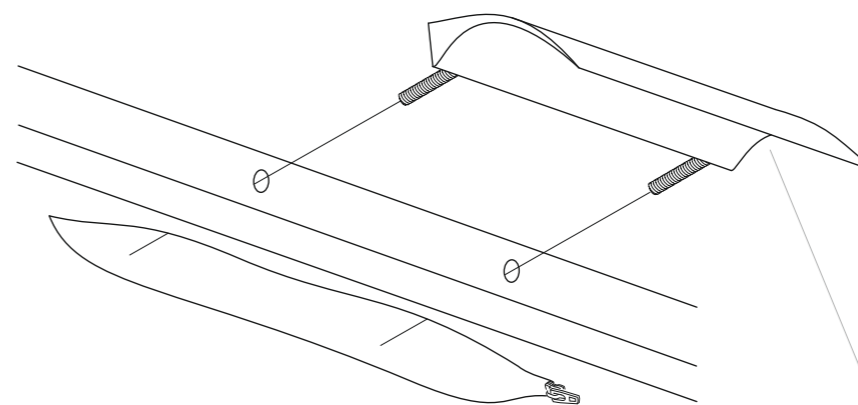
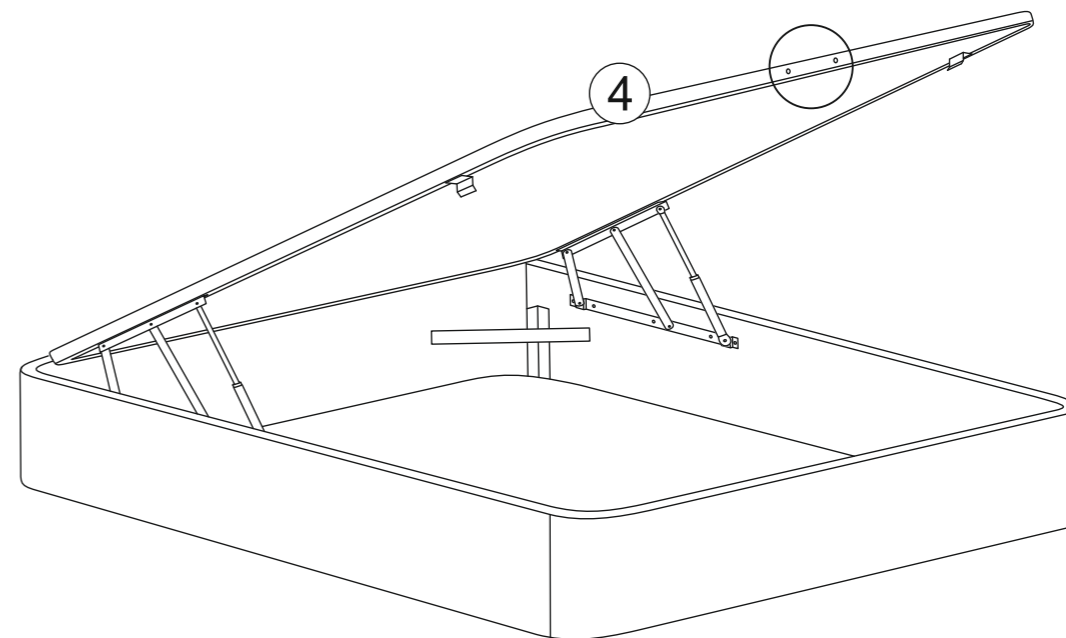

8

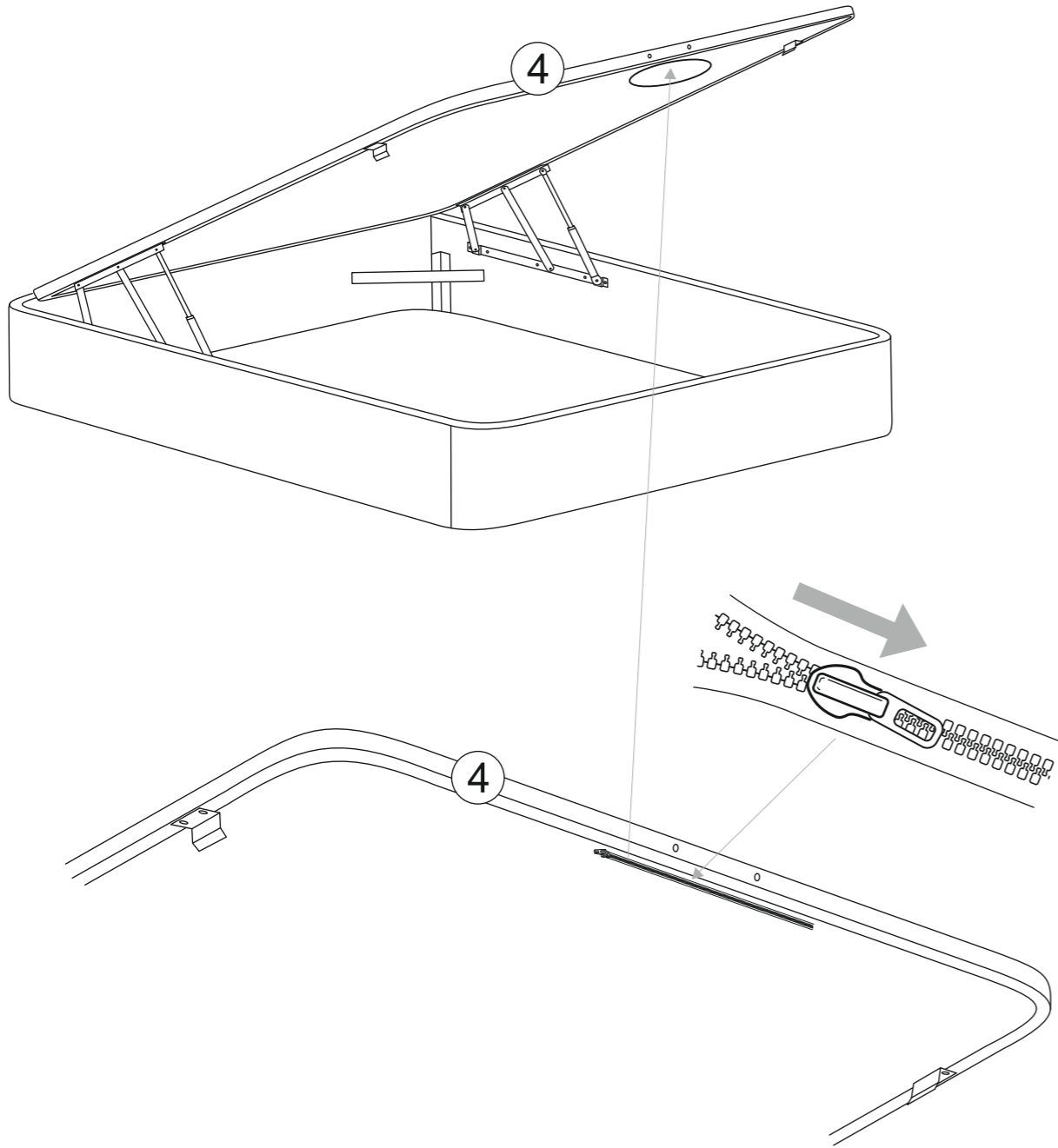

9

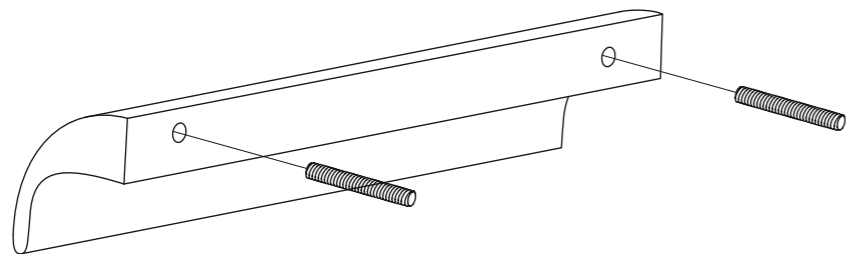

Lx1



Fx2

M4x70mm

5

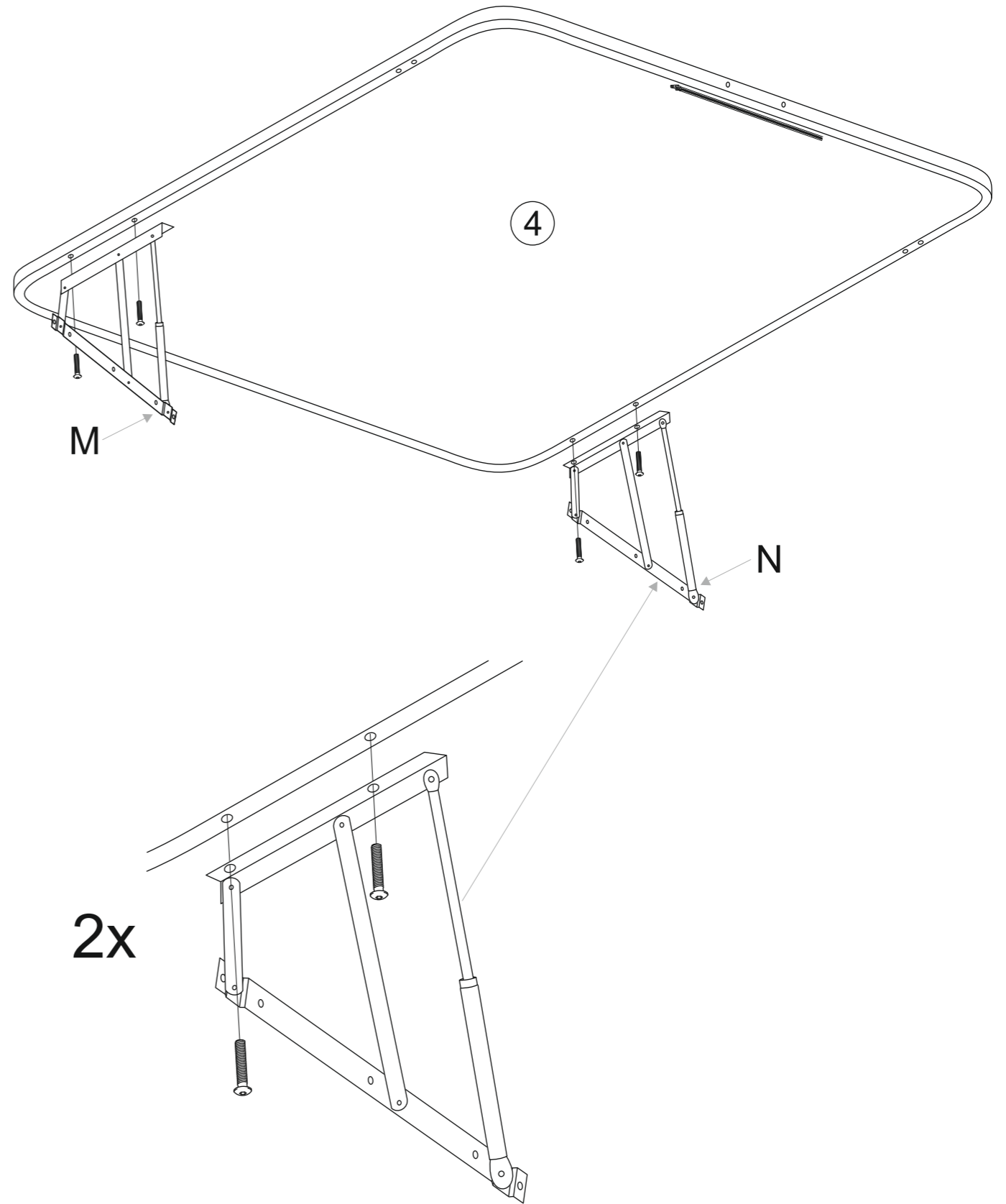

M

N

2x

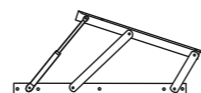

Mx1

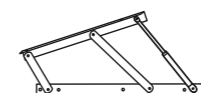

Nx1



Bx4

M6x35mm

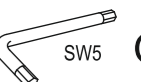

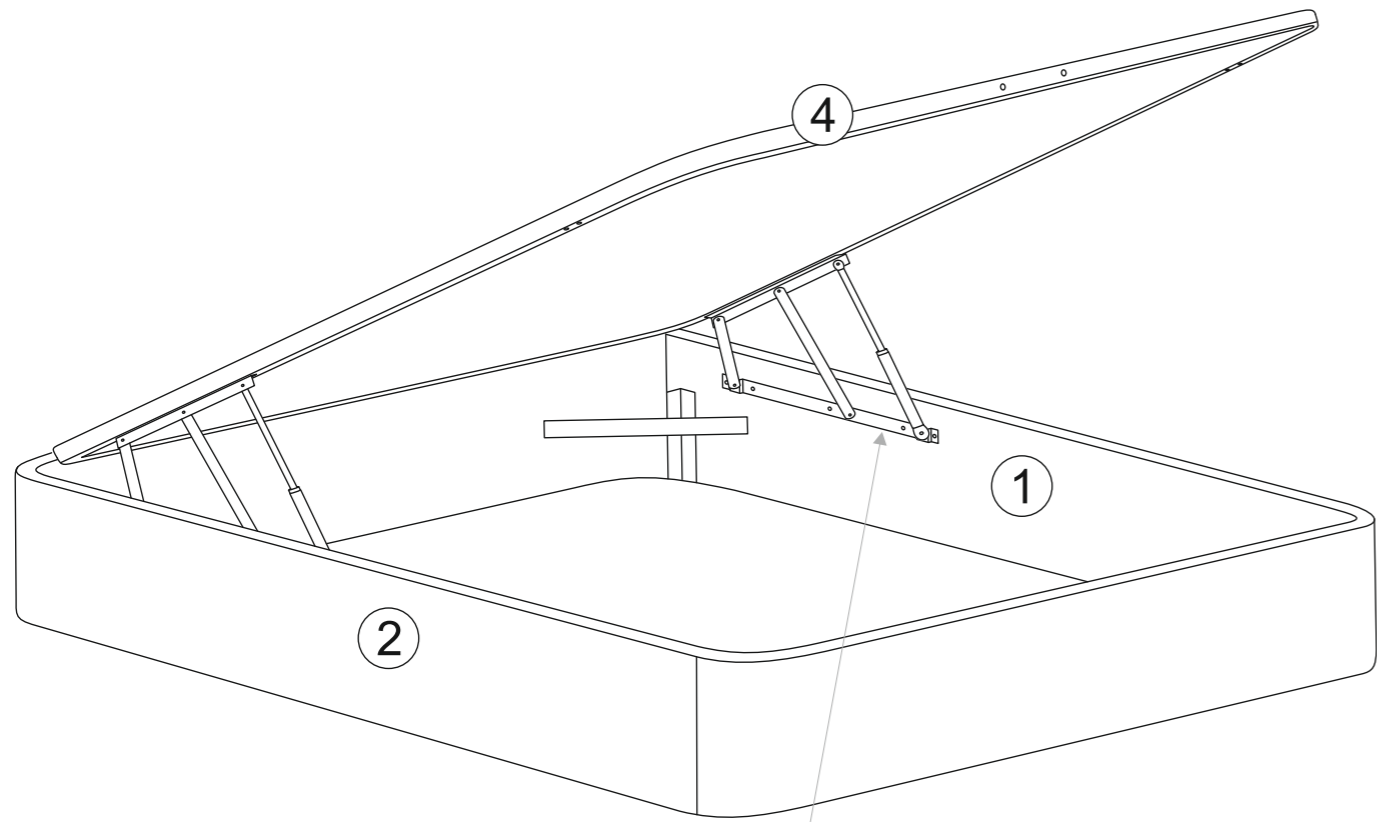

SW5 Q

6

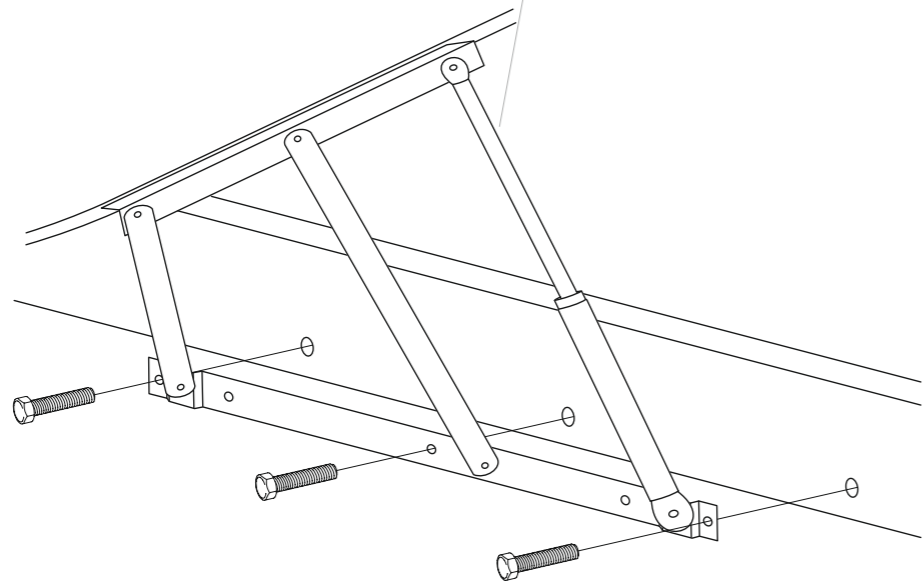

2x

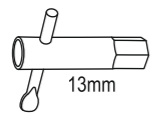

 Ax6  
M8x35mm

 R  
13mm

7

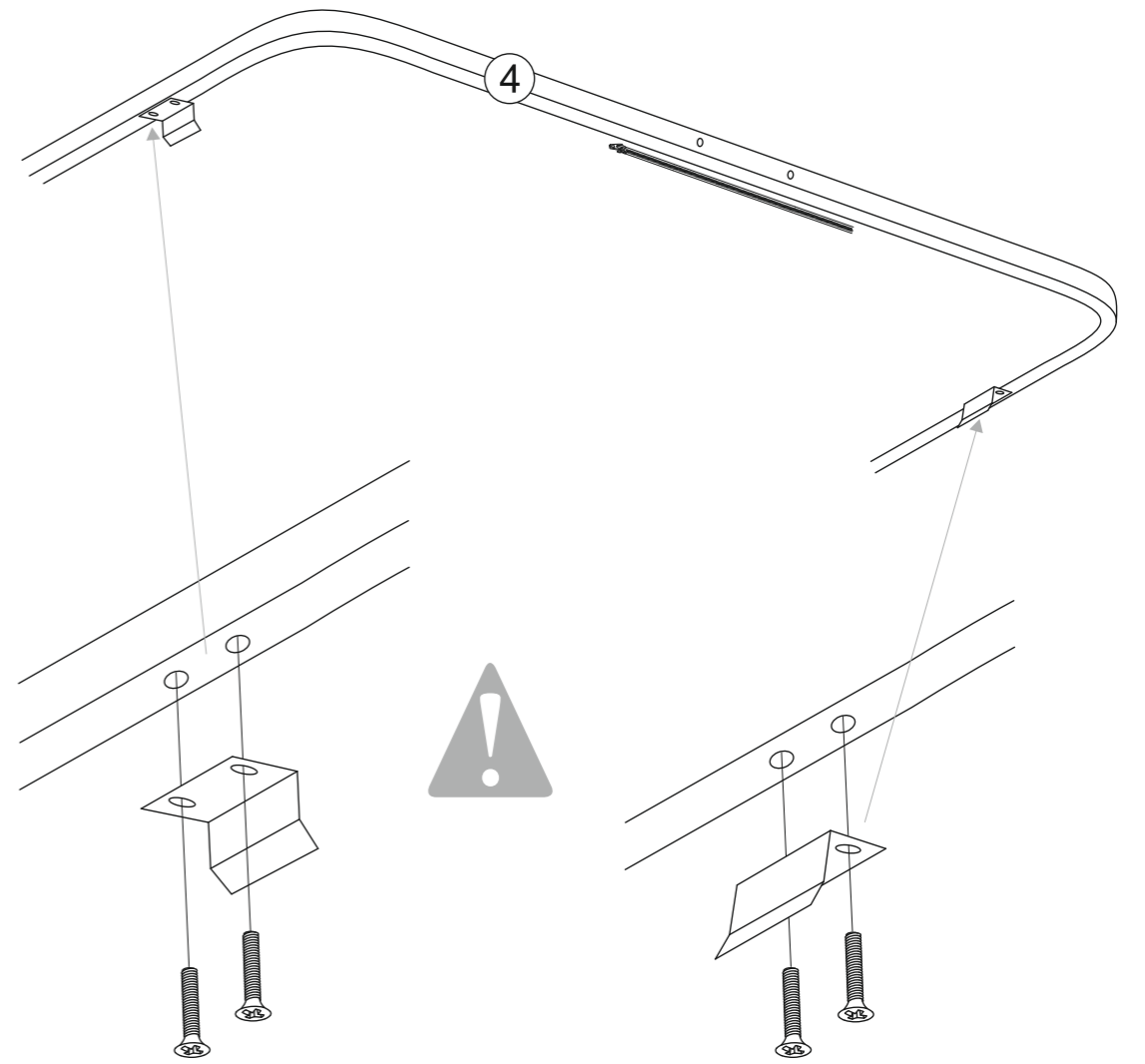
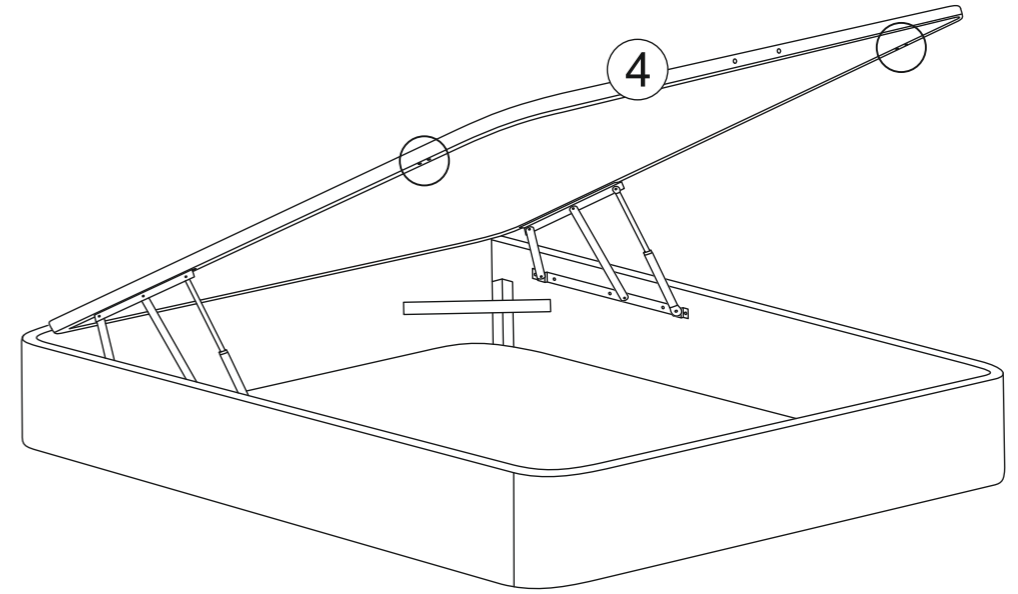

 Jx2

 Ex4  
M6x30mm

