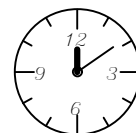
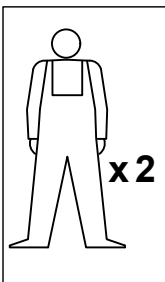


UPUTSTVO ZA MONTIRANJE
 ASSEMBLING INSTRUCTION
 MONTAGEANLEITUNG
 INSTRUCTIONS D'ASSEMBLAGE
 INSTRUCCIONES DE MONTAJE
 ISTRUZIONI PER L'INSTALLAZIONE
 ИНСТРУКЦИЈА ПО МОНТАЖУ
 MONTÁŽNÍ NÁVOD
 ΟΔΗΓΙΕΣ ΣΥΝΑΡΜΟΛΟΓΗΣΗΣ

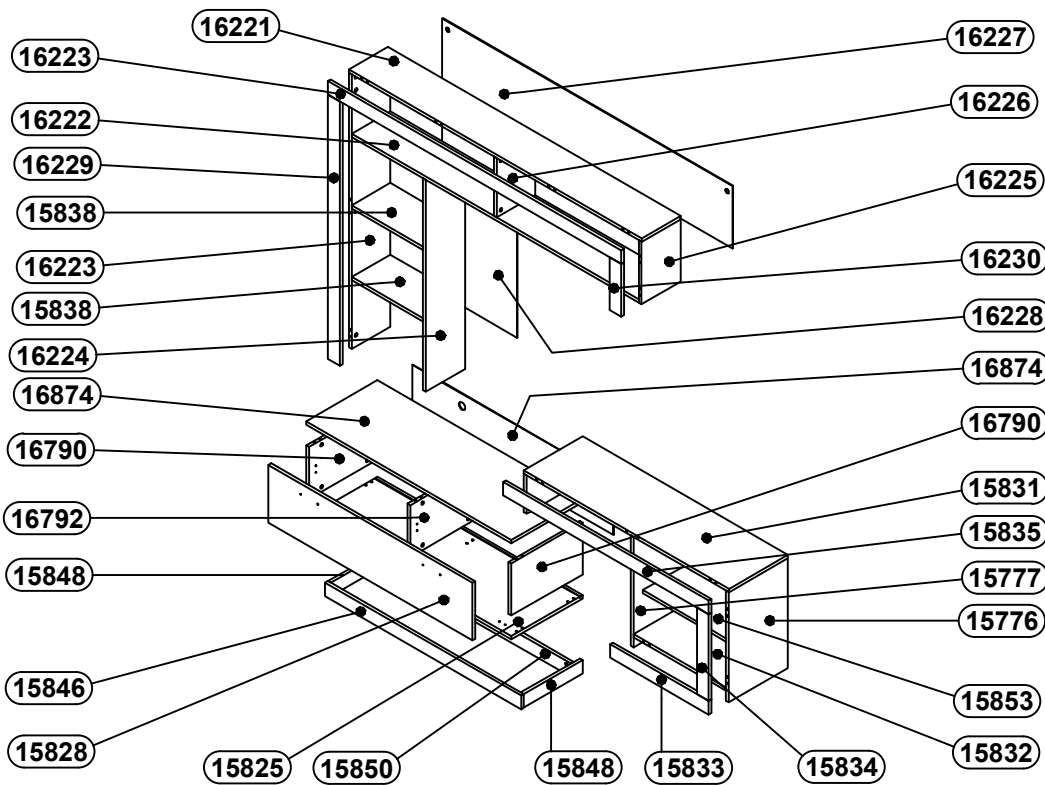
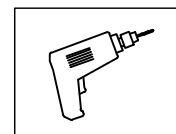
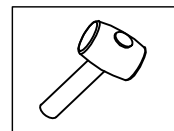
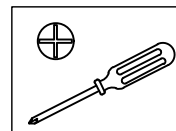
INSTRUCȚIUNI DE MONTAJ
 ИНСТРУКЦИЈА ЗА МОНТАЖ
 SZERELÉSI UTASÍTÁS
 NAVODILA ZA MONTAŽO
 UPUTE ZA MONTAŽU
 UPUTSTVO ZA MONTIRANJE
 УПАТСТВО ЗА МОНТИРАЊЕ
 UDHËZIMET PËR MONTIM

GLEN

CODE : UP 00341
 Version: 01_04032016



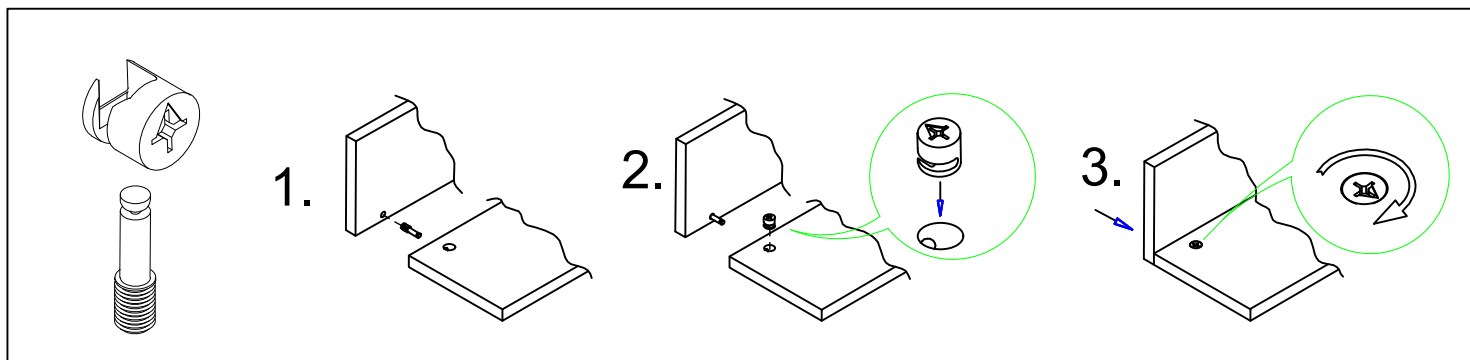
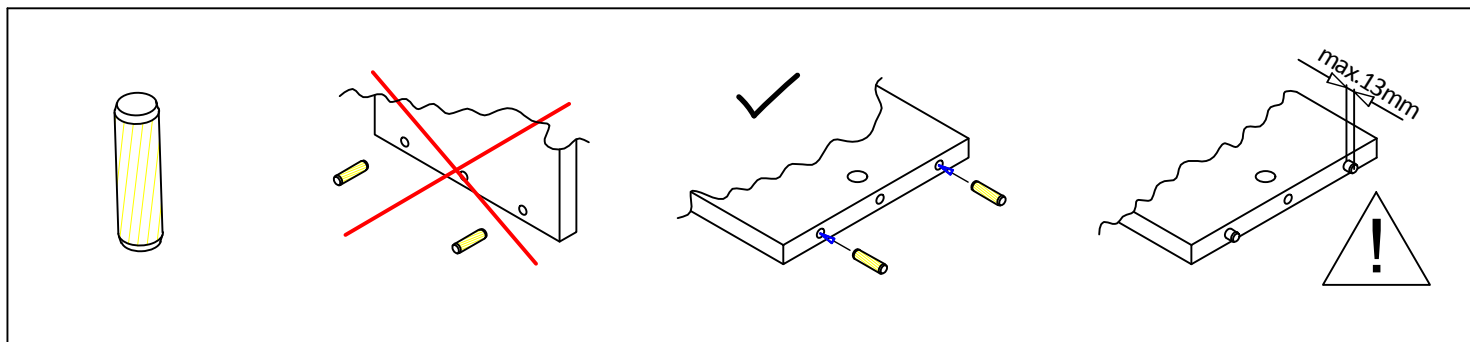
40 min



RS ME
 PRE POČETKA MONTIRANJA OBAVEZNO PROČITAJTE UPUTSTVO ZA MONTAŽU
UK
 BEFORE STARTING, REFER TO THE ASSEMBLING ADVICE IN ANNEX
DE AT CH
 VOR DER MONTAGE BITTE BEILIEGENDE ANWEISUNGEN LESEN
FR CH
 AVANT LE DÉBUT DE L'ASSEMBLAGE, S'IL VOUS PLAÎT, LISEZ L'INSTRUCTION D'ASSEMBLAGE
ES
 ANTES DE EMPEZAR EL MONTAJE, LEER CUIDADOSAMENTE LAS INSTRUCCIONES DEL ANEXO
IT CH
 PRIMA DI INIZIARE L'INSTALLAZIONE SI RACCOMANDA DI LEGGERE LE ISTRUZIONI DI INSTALLAZIONE
RUS
 ДО НАЧАЛА МОНТАЖА ОЗНАКОМЬТЕСЬ С ИНСТРУКЦИЕЙ
CZ
 SEZNAMTE SE S NÁVODEM PŘED MONTÁŽÍ NÁBYTKU
EL
 ΠΡΙΝ ΞΕΚΙΝΗΣΕΤΕ ΤΗ ΣΥΝΑΡΜΟΛΟΓΗΣΗ, ΟΠΟΣΔΗΠΟΤΕ ΔΙΑΒΑΣΤΕ ΤΙΣ ΟΔΗΓΙΕΣ ΣΥΝΑΡΜΟΛΟΓΗΣΗΣ
RO
 ÎNAINTE DE ÎNCEPEREA MONTAJULUI ESTE OBLIGATORIE CITIREA INSTRUCȚIUNILOR
BG
 ПРЕДИ МОНТИРАНЕ НЕ ЗАБРАВЯЙТЕ ДА СК ЧЕТЕ ИНСТРУКЦИИ ЗА МОНТАЖ
HU
 SZERELÉS ELŐTT ÖKVELTENÜL OLVASSA EL A HASZNÁLATI UTASÍTÁST
SI
 PRED ZAČETKOM MONTAŽE OBEVZNO PREBERITE NAVODILA
HR
 PRIJE MONTAŽE UPOZNATI SE SA UPUTSTVOM
BIH
 PRE POČETKA MONTIRANJA OBAVEZNO PROČITAJTE UPUTSTVO ZA MONTAŽU
MK
 ПРЕД ПОЧЕТОК НА МОНТИРАЊЕ ЗАДОЛЖИТЕЛНО ДА СЕ ПРОЧИТА УПАТСТВОТО ЗА МОНТИРАЊЕ
AL
 PARA FILLIMIT TË MONTIMIT LEXONI PATJETËR UDHËZIMIN PËR MONTIM

A	Ø8x30	B	C	D	E	F	G	Ø6.3x13	H	4x16	I	J
x64		x56		x56	x3	x2	x4	x24	x3	x4		
K	3x16	L	M	N	O	Ø5x30	P	Q	R	6x60	S	1.6 x 25
x8		x6	x34	x4	x4	x2	P1	x2	x2	x37	x2	
U	3x25	V	W	4x30	X	Y						
x2		x2	x4		x8							

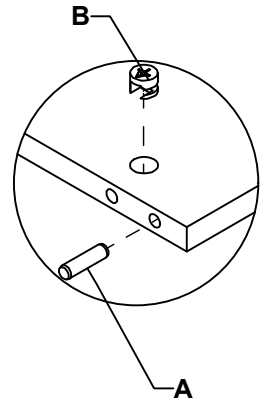
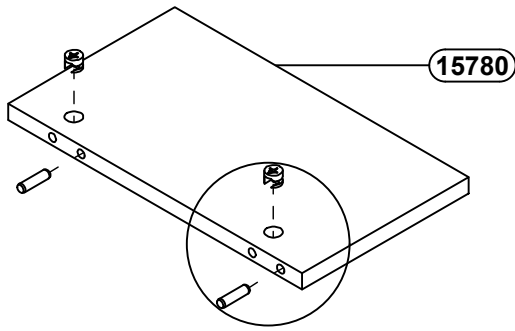
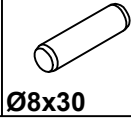
<p>RS ME</p> <p>1. Montažu obavljati na čistoj i mekoj podlozi (karton, tkanina...)</p> <p>2. Da bi izbegli oštećenja elemenata pridržavati se datih instrukcija.</p> <p>3. Prilikom prijave reklamacije koristiti date oznake elemenata.</p>	<p>UK</p> <p>1. Assembly of the product should be done on a clean and soft surface (cardboard, fabric)</p> <p>2. To prevent damage of the product, it is necessary to adhere to the assembly instructions</p> <p>3. While reporting defective products, please quote codes in manual</p>
<p>DE AT CH</p> <p>1. Die Montage soll auf sauberer, weicher Fläche durchgeführt werden (Karton, Stoff)</p> <p>2. Um die Beschädigung der Elemente zu vermeiden, befolgen Sie bitte die angegebenen Instruktionen</p> <p>3. Bei Reklamationsmeldungen benutzen Sie bitte die angegebenen Kennzeichen der Elemente</p>	<p>FR CH</p> <p>1. Effectuer l'assemblage sur une surface propre et douce (carton, tissu...)</p> <p>2. Afin d'éviter l'endommagement des éléments, respectez les instructions données.</p> <p>3. Lors de l'application de réclamation, utiliser les désignations données des éléments.</p>
<p>ES</p> <p>1. Realizar el montaje sobre una superficie limpia y suave (cartón, paño)</p> <p>2. Para evitar daños del producto, atenerse a las instrucciones de montaje</p> <p>3. Para reportar productos defectuosos, refiérase por favor a los códigos del manual</p>	<p>IT CH</p> <p>1. Eseguire l'installazione su una base morbida (cartone, tessuto).</p> <p>2. Seguire le istruzioni per evitare di causare danni agli elementi.</p> <p>3. In caso della presentazione di reclamo si utilizzano relative indicazioni degli elementi.</p>
<p>RUS BLR</p> <p>1. Монтаж изделия выполнять на чистой и мягкой поверхности (картон, ткань)</p> <p>2. Для предотвращения порчи изделий необходимо придерживаться правил монтажа</p> <p>3. В случае предъявления претензии использовать данные обозначения элементов.</p>	<p>CZ SK</p> <p>1. Montáž provádět na čistém a měkkém podkladu (lepenka, látka)</p> <p>2. Dodržujte přiložené instrukce, abyste předešli poškození součástí</p> <p>3. Při reklamaci používejte přiložené označení element</p>
<p>EL</p> <p>1. Η συναρμολόγηση του προϊόντος πρέπει να γίνει σε καθαρή και μαλακή επιφάνεια (χαρτόνι, ύφασμα).</p> <p>2. Για να μην φθαρούν τα στοιχεία, συμμορφωθείτε με τις οδηγίες που παρέχονται.</p> <p>3. Κατά τη δήλωση ελαττωματικού προϊόντος, αναφέρετε τους κώδικες των στοιχείων όπως αναφέρονται στο εγχειρίδιο.</p>	<p>RO</p> <p>1. Montarea se efectueaza pe o suprafata moale si curata (carton, material..)</p> <p>2. Respectati instructiunile pentru a evita deteriorarea pieselor</p> <p>3. La transmiterea reclamatiiilor a se folosi inscriptiile date ale pieselor</p>
<p>BG</p> <p>1. Монтажът трябва да бъде извършен върху чиста и мека основа /картон, тъкан/</p> <p>2. За да избегнете оцетяване на елементи, спазвайте дадените инструкции</p> <p>3. При наличие на рекламация, използвайте дадените кодове на елементи</p>	<p>HU</p> <p>1. A szerelés tisztá es puha felületen (karton, anyag) kell végrehajtani.</p> <p>2. Károsodásnak elkerülése érdekében, tartsa be a megadott utasításokat.</p> <p>3. Reklamáció esetén hivatkozzon a bútor alkatrészein megadott jelekre.</p>
<p>SL</p> <p>1. Montažo opravimo na čisti in mehki podlogi (karton, tkanina)</p> <p>2. Da bi se ozognili poškodbam elementov, upoštevajte navodila.</p> <p>3. Pri reklamaciji uporabimo oznake elementov</p>	<p>HR BIH</p> <p>1. Montažu obavljati na čistoj i mekoj podlozi (karton, tkanina)</p> <p>2. Da bi izbegli oštećenja elemenata pridržavati se datih instrukcija</p> <p>3. Prilikom prijave reklamacije koristiti date oznake elemenata</p>
<p>MK</p> <p>1. Монтажа да се врши на чиста и мека подлога (картон, ткаенина)</p> <p>2. За да се избегне оштетување на елементите придржувајте се на дадените инструкции</p> <p>3. За пријава на рекламации користете ги дадените ознаки на елементите</p>	<p>AL</p> <p>1. Montimi të bëhet në sipërfaqe të pastër dhe të butë (karton, pëlhurë)</p> <p>2. Që t'u shmangeni dëmtimit të elementeve, përmbahuni instrukcioneve të dhëna</p> <p>3. Me rastin e reklamimit përdorni shenjat e dhëna të elementit</p>



1

A x 2

B x 2

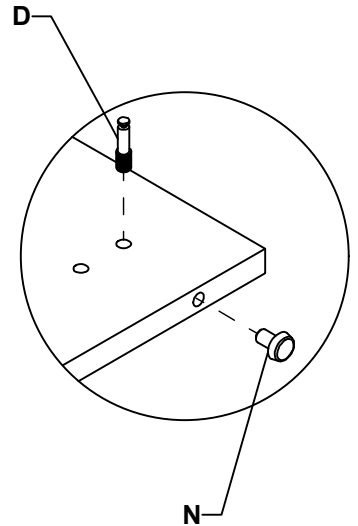
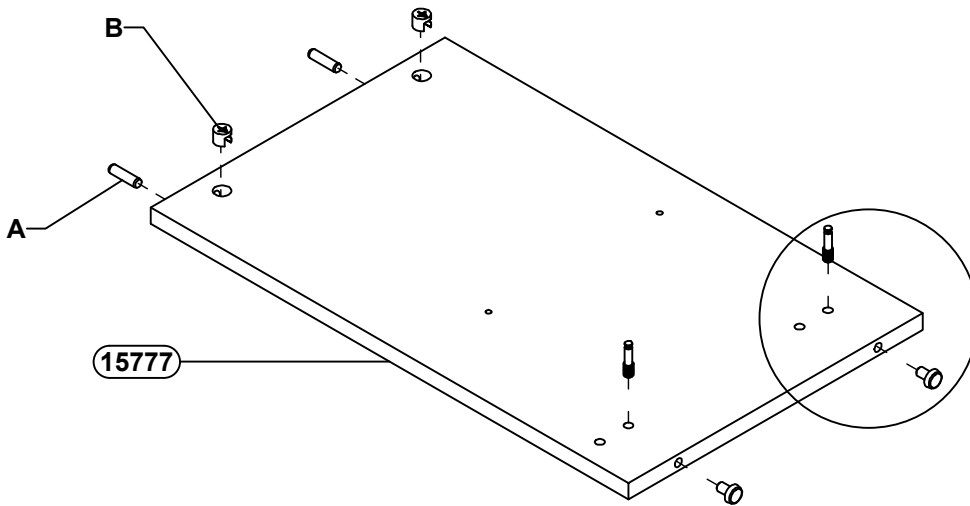
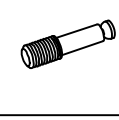
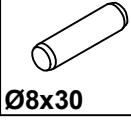
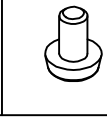
**2**

N x 2

A x 2

B x 2

D x 2

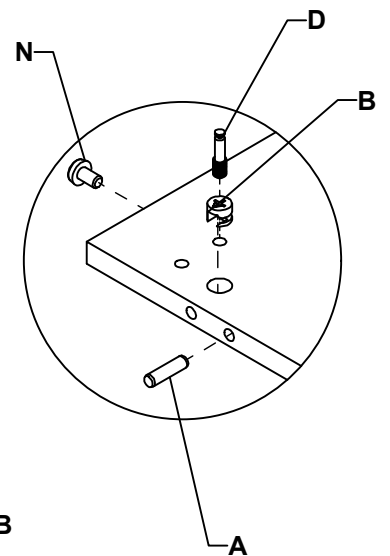
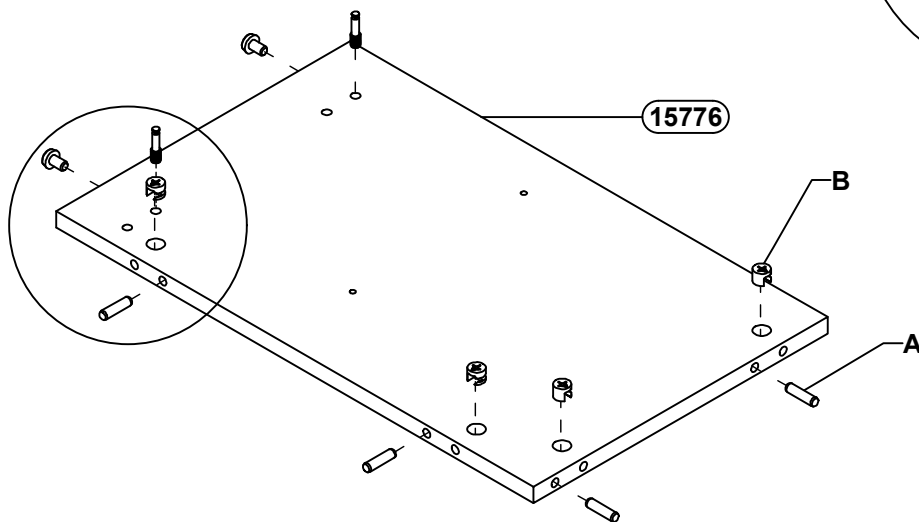
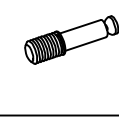
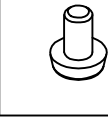
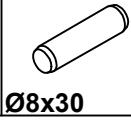
**3**

A x 4

B x 4

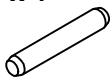
N x 2

D x 2

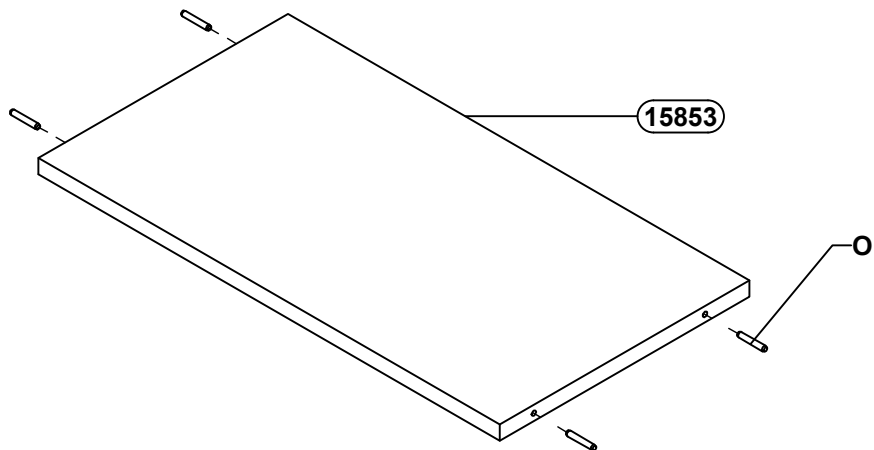


4

O x 4



Ø5x30



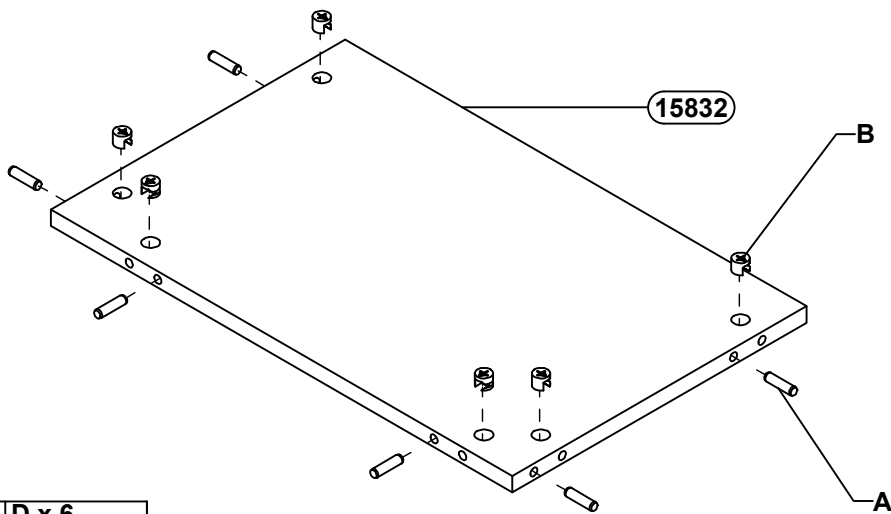
5

A x 6



Ø8x30

B x 6



6

A x 3

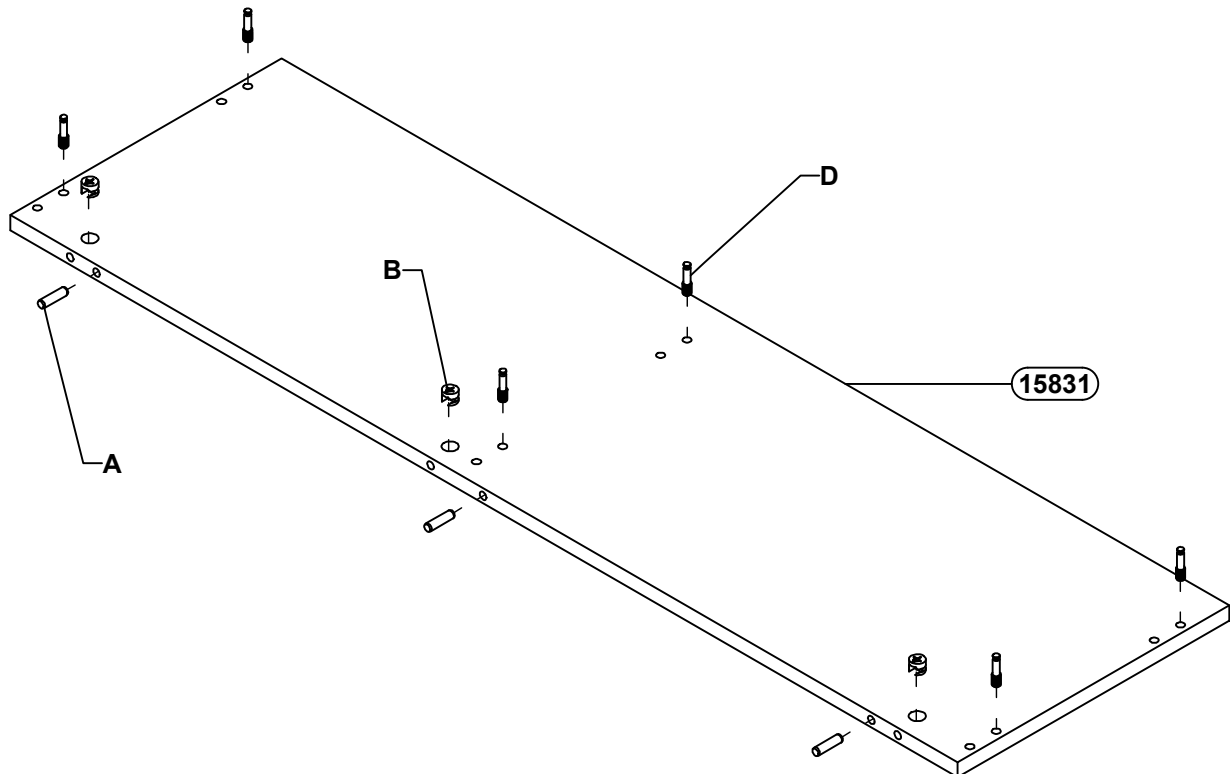


Ø8x30

B x 3

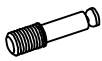


D x 6



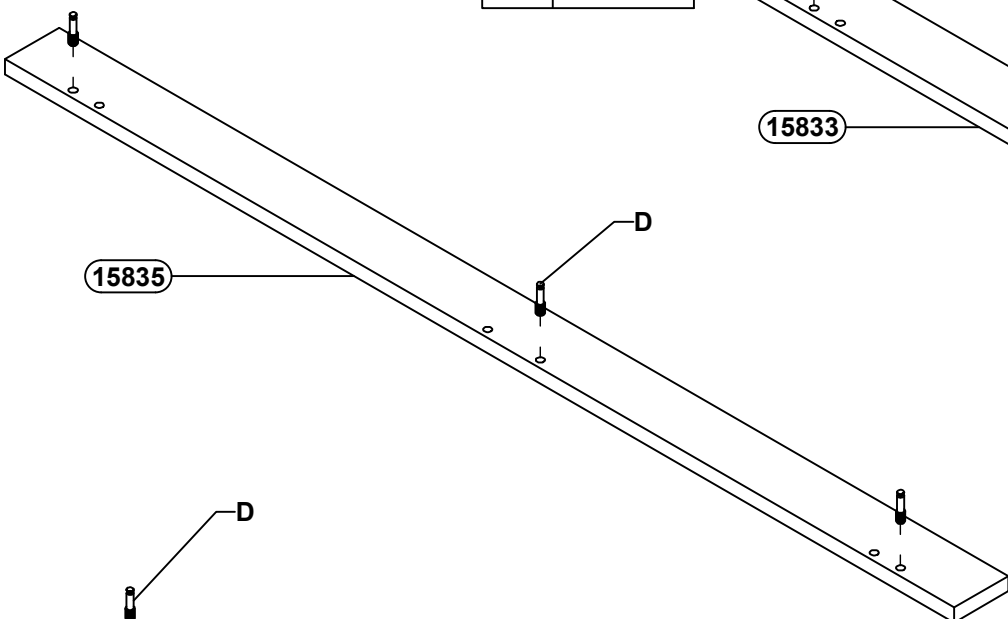
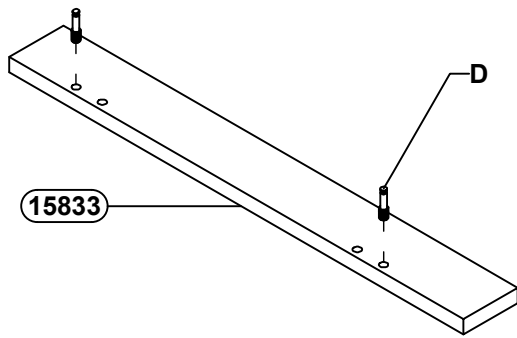
7

D x 3



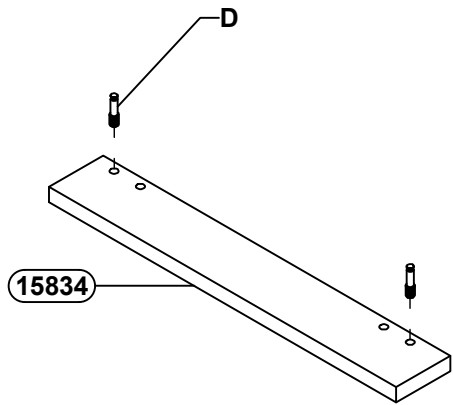
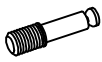
8

D x 2

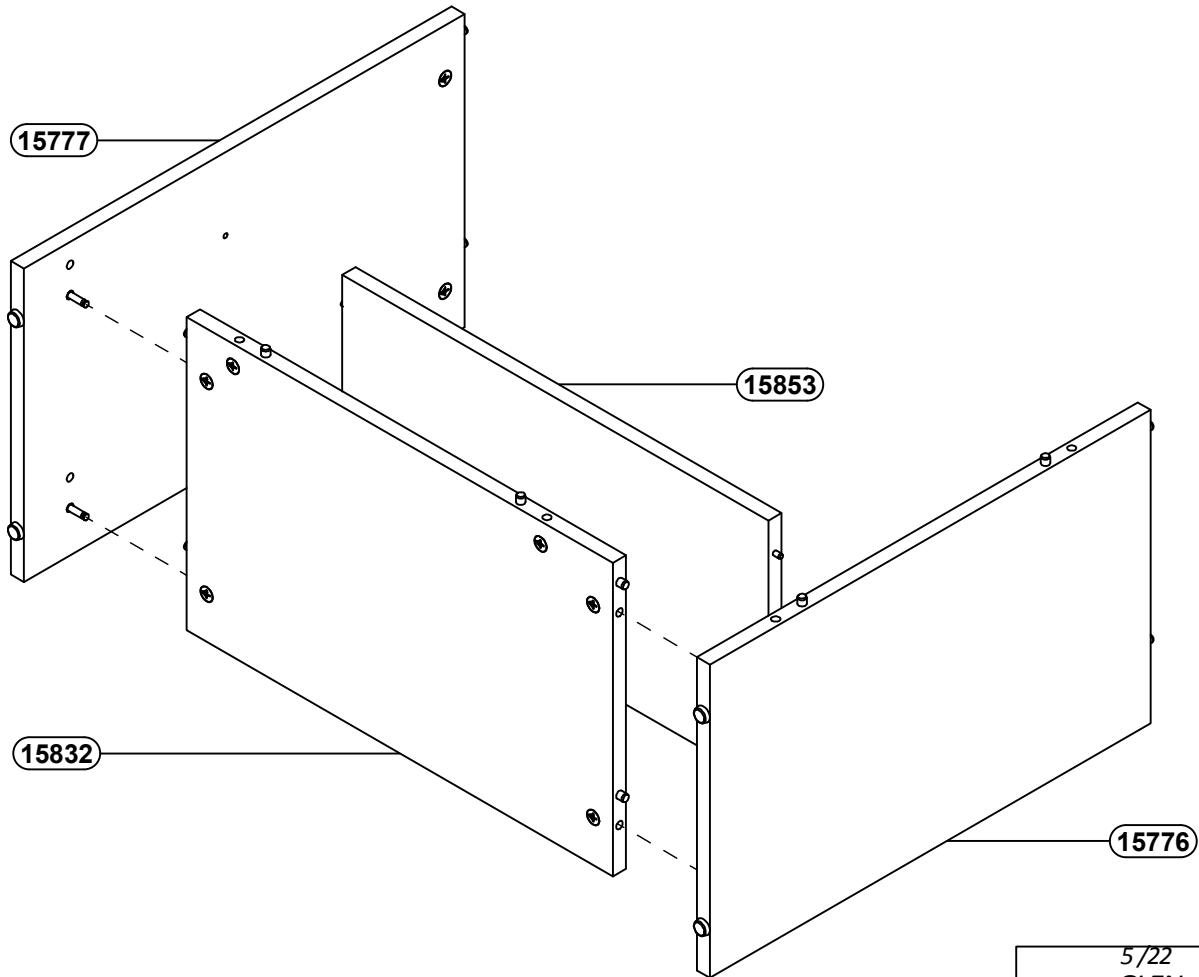


9

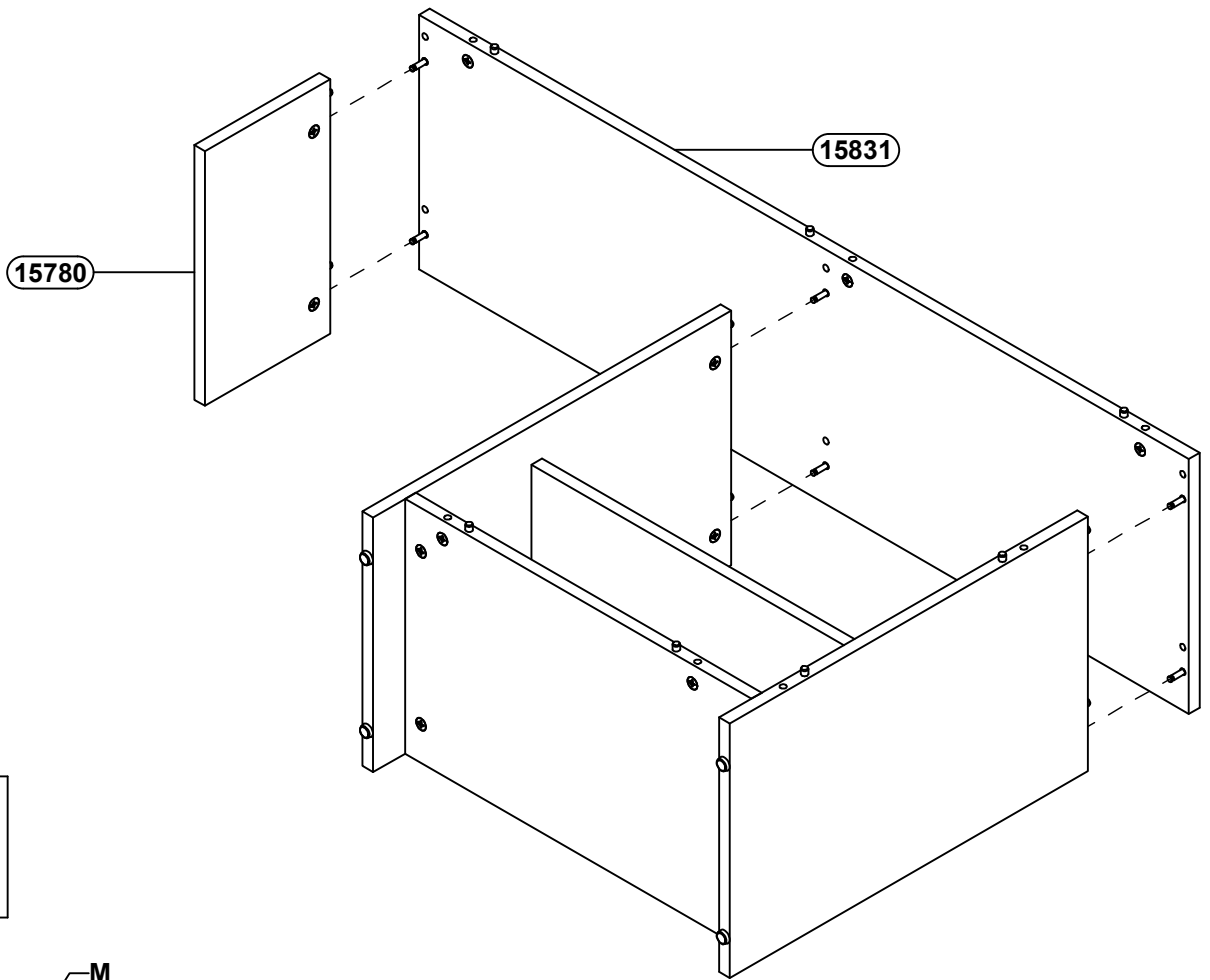
D x 2



10

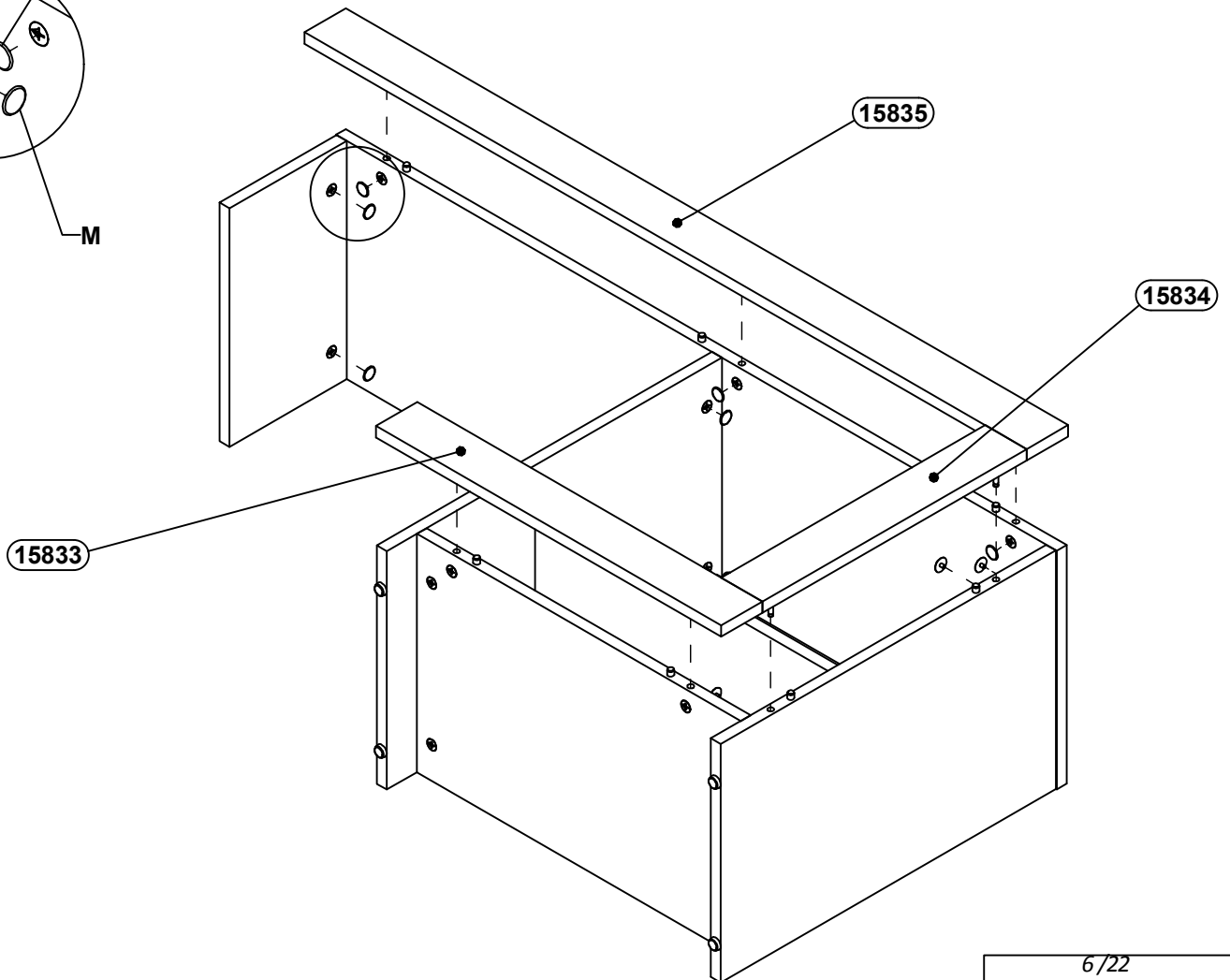
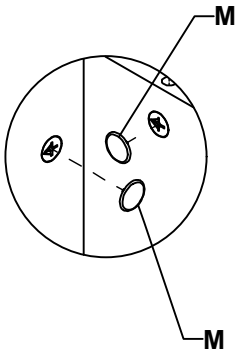




11





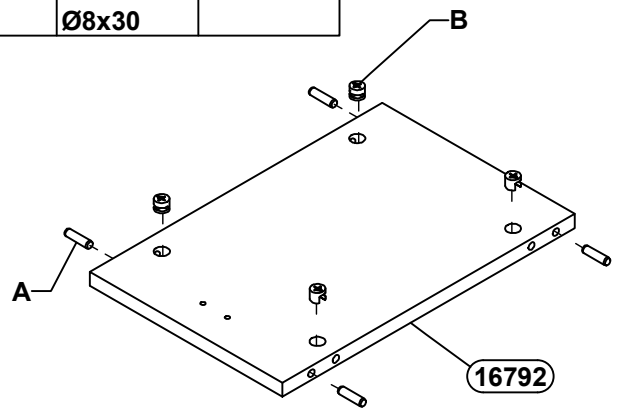
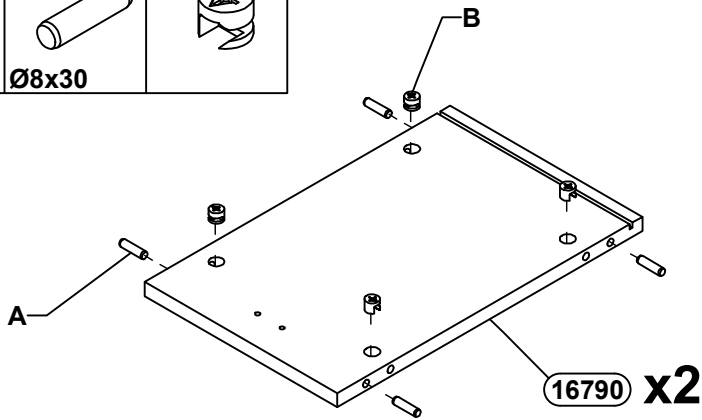
12 M x 11

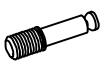

Diagram 12 shows a circular washer or spacer. It is a simple ring with a central hole. The text "M x 11" indicates its size and compatibility with the assembly.

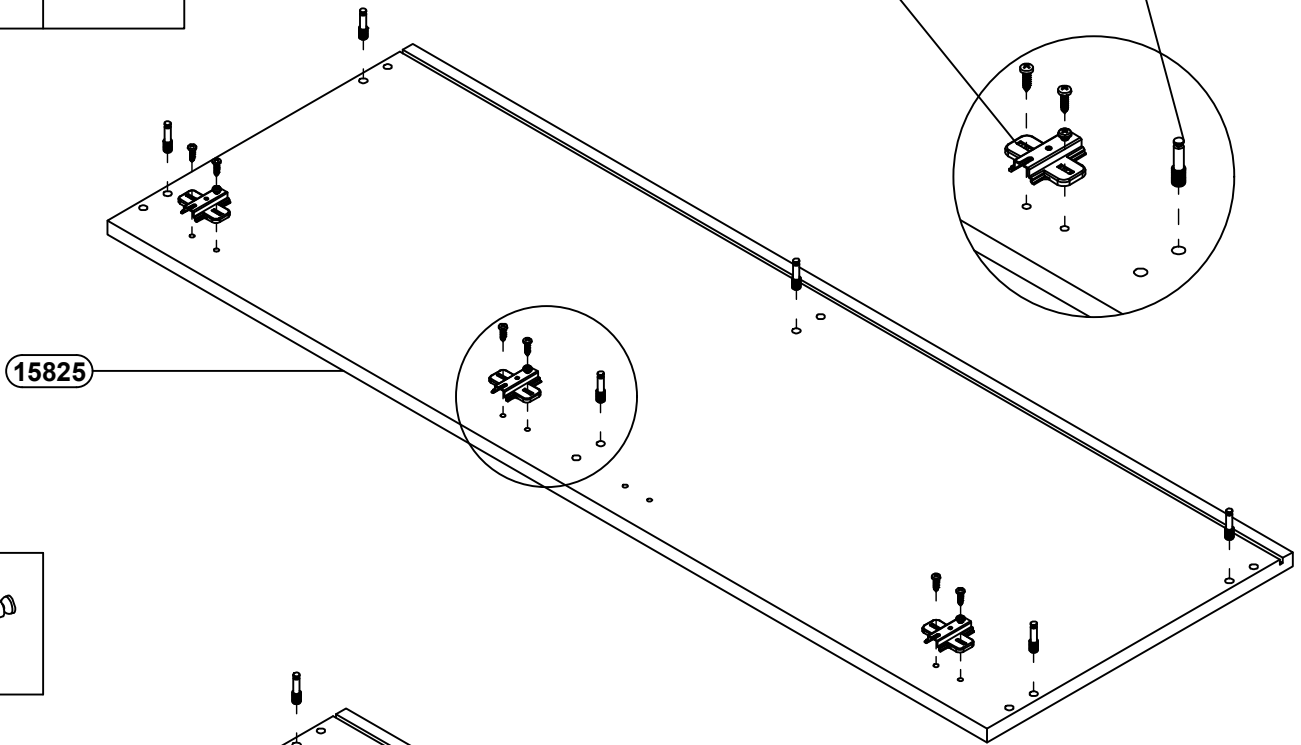


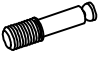
13 A x 8 B x 8
 
 Ø8x30

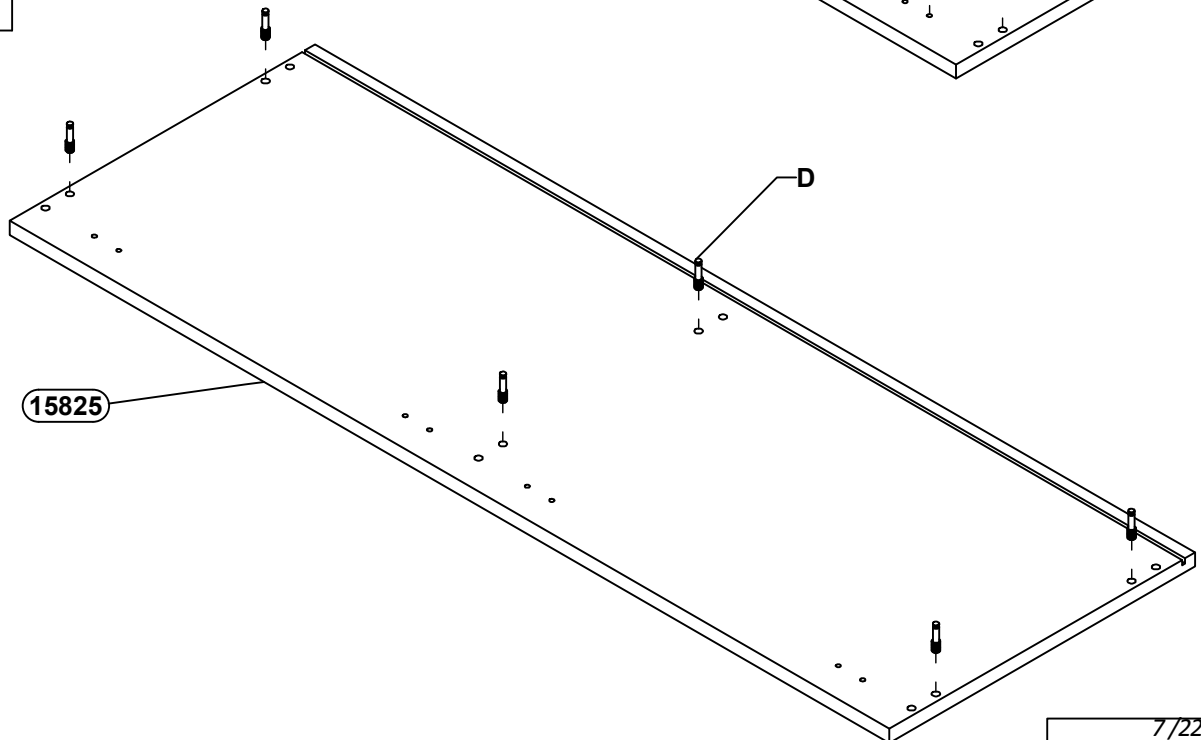
14 A x 4 B x 4
 
 Ø8x30



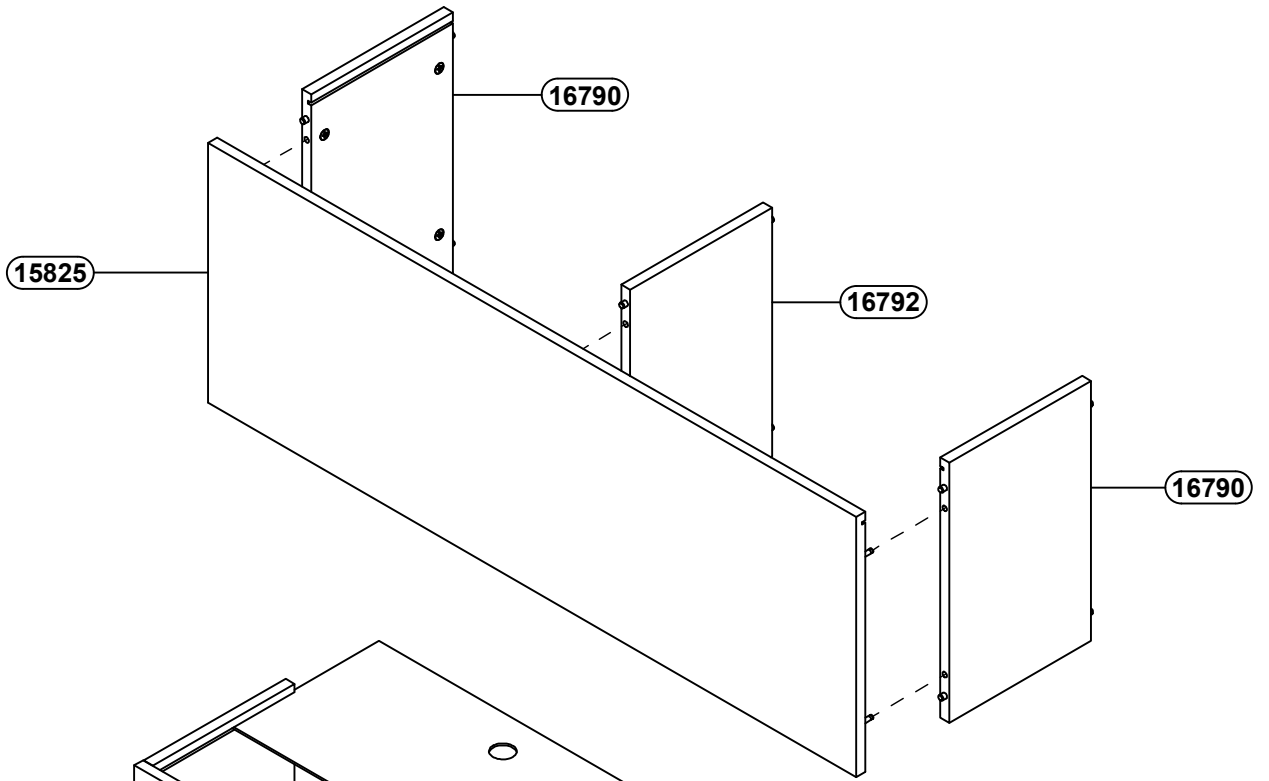
15 D x 6 E x 3
 



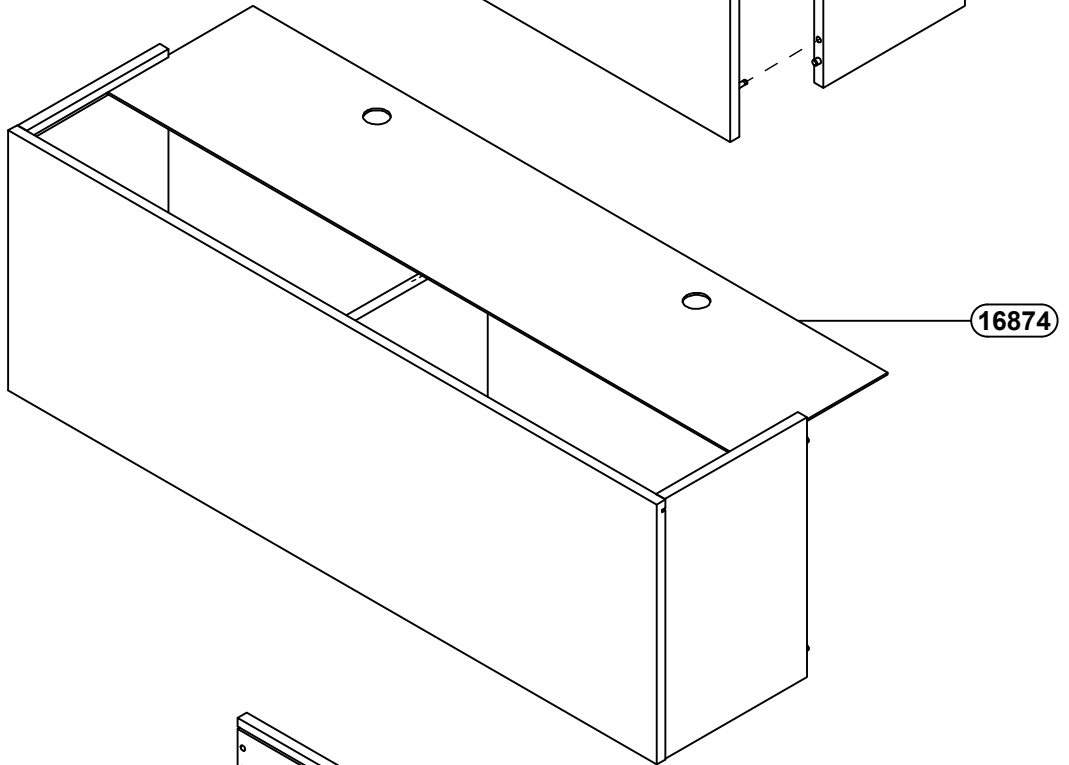
16 D x 6




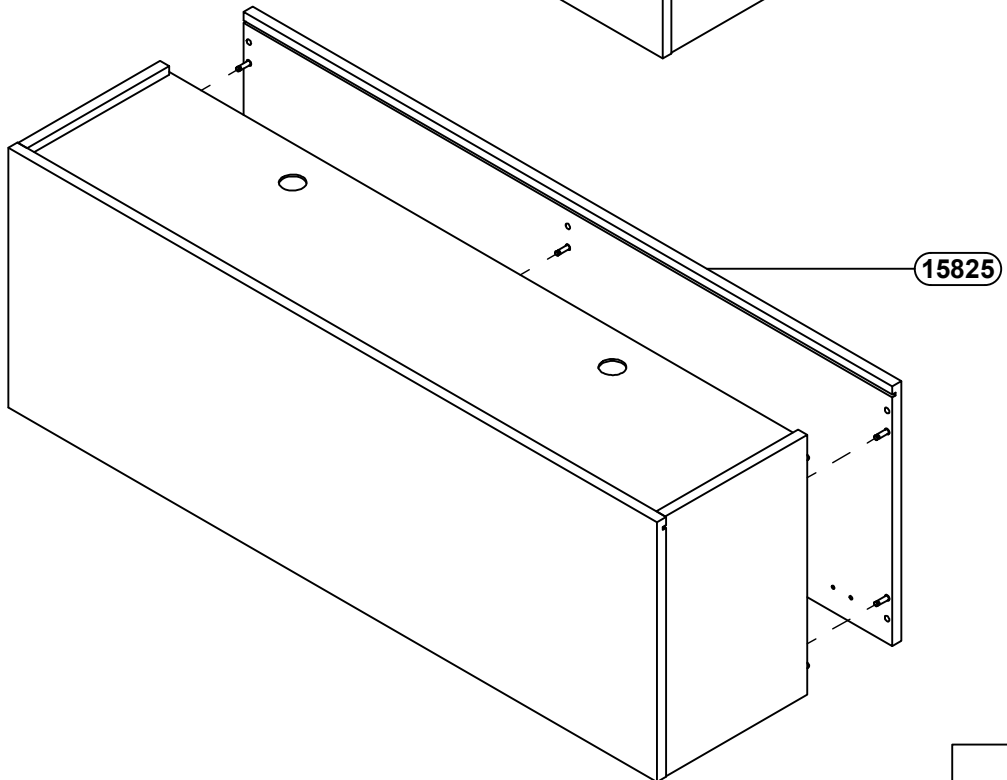
17



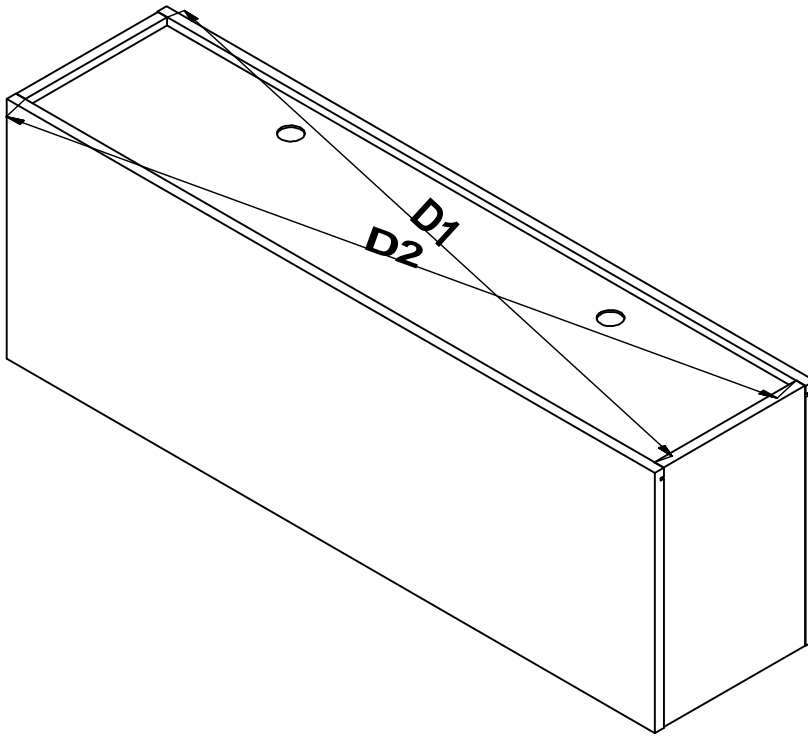
18



19



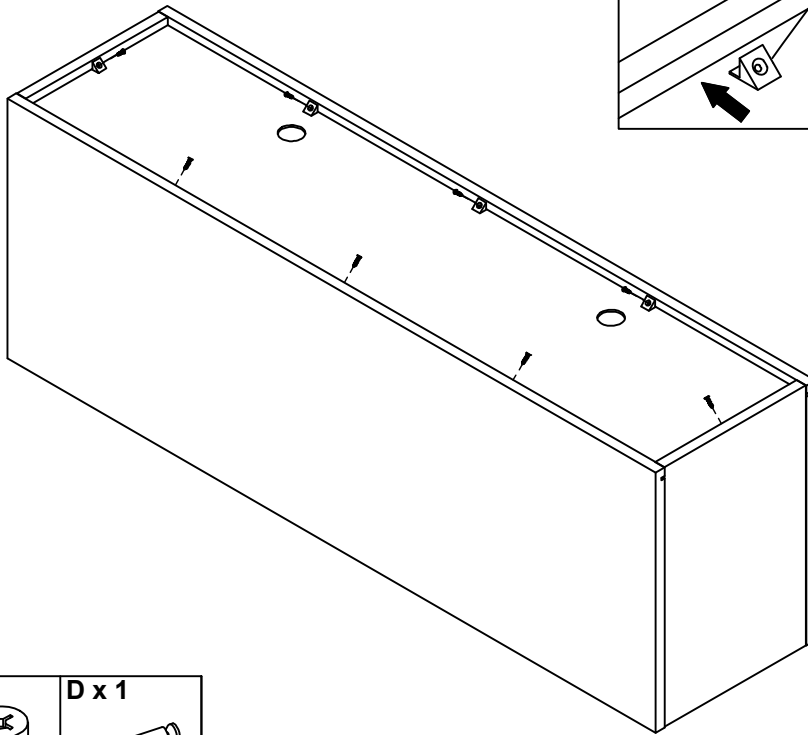
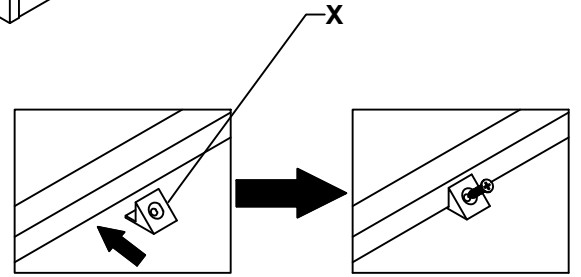
20



D1=D2

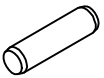
21

X x 8



22

A x 1

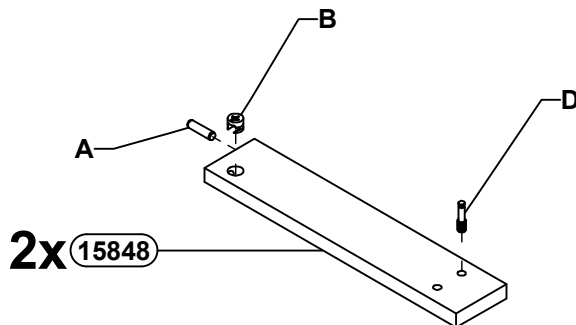
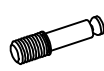


Ø8x30

B x 1



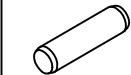
D x 1



23

A x 2

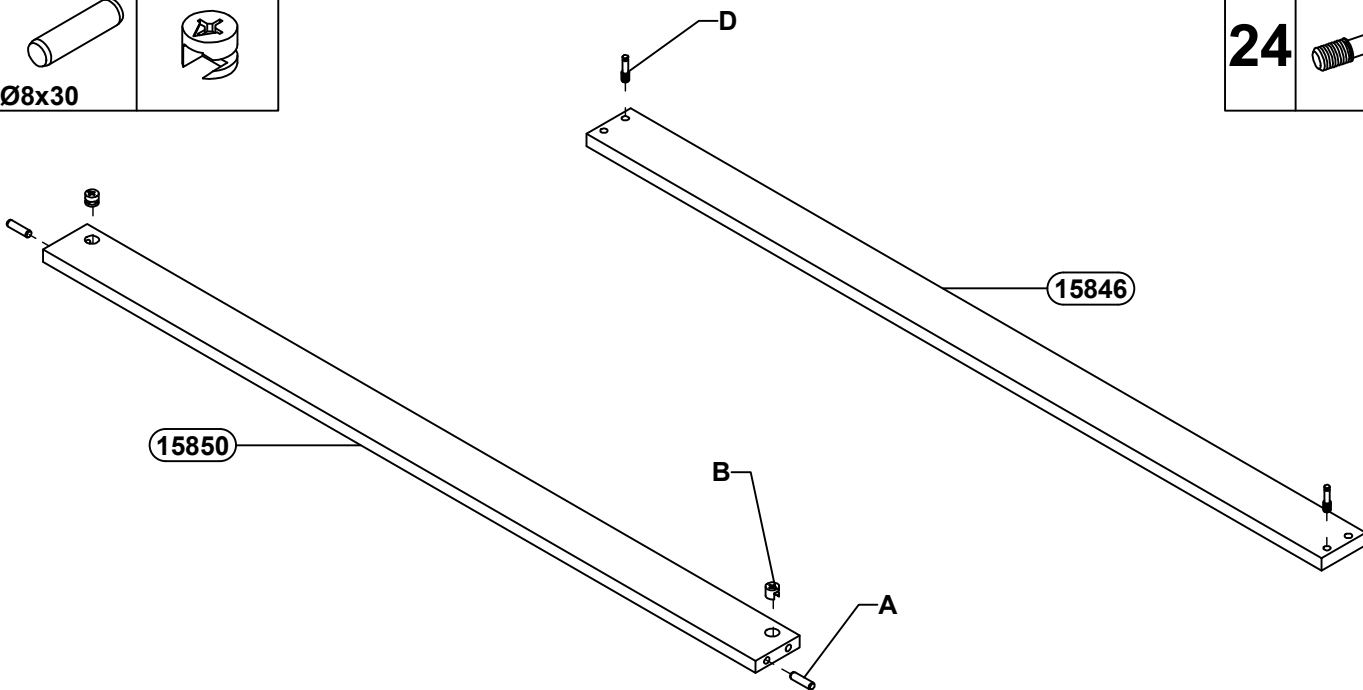
B x 2



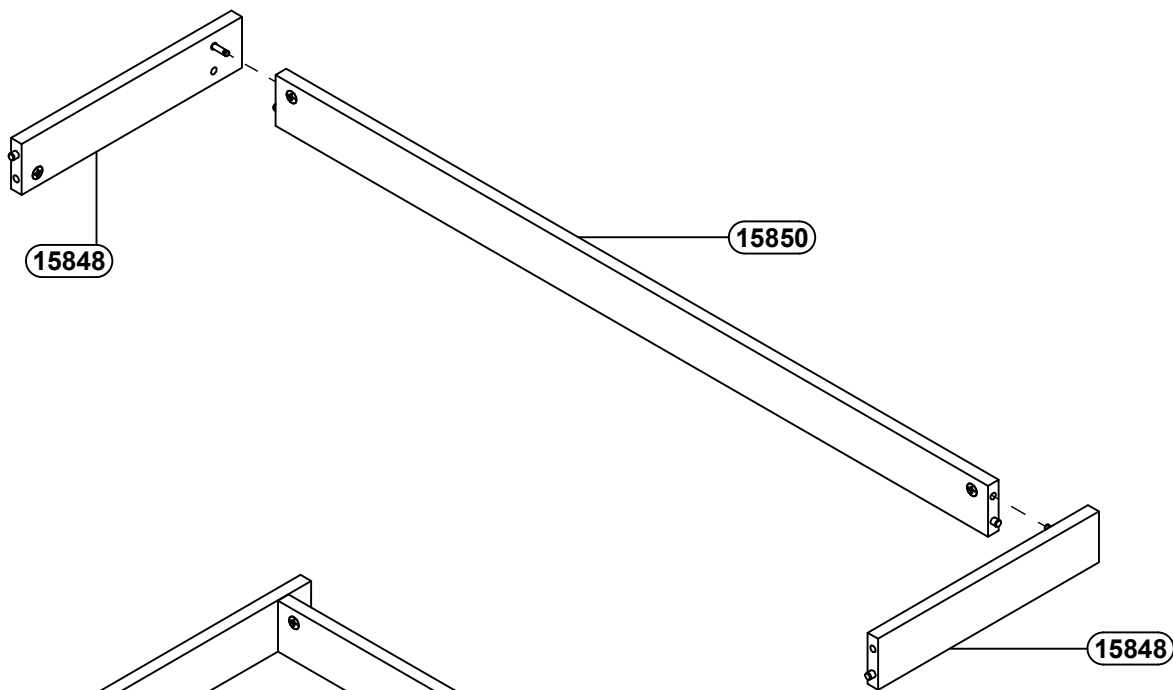
Ø8x30

24

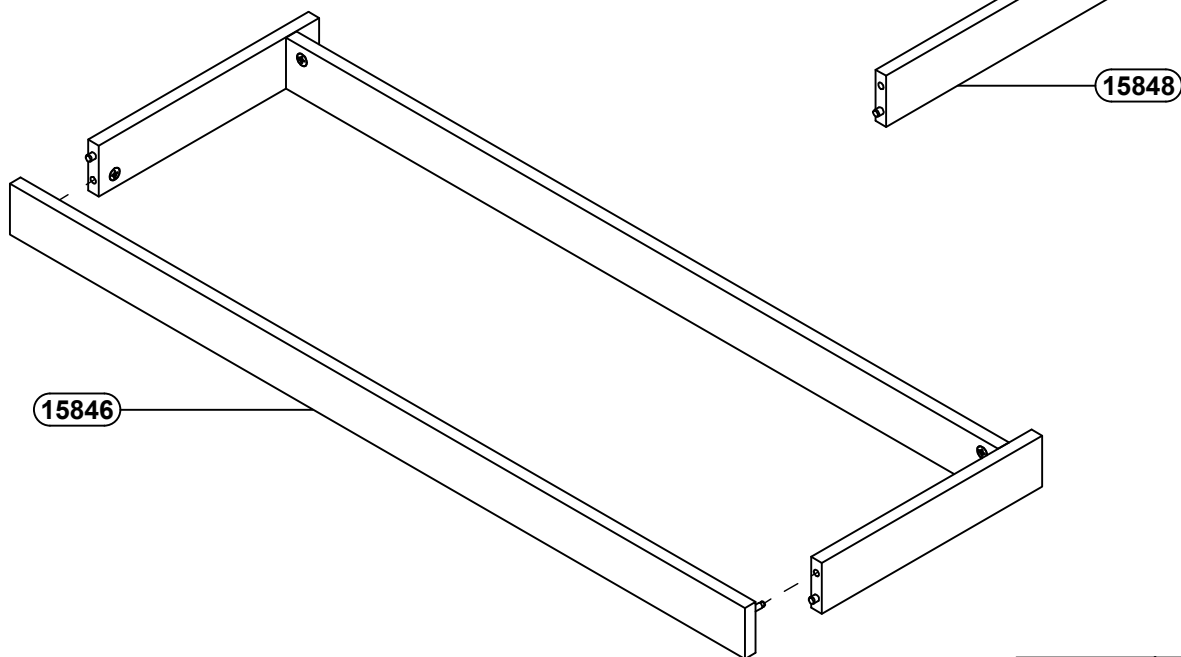
D x 2



25



26

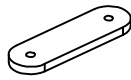


27

C x 12



J x 4



K x 8



3x16

H x 12



4x16

L x 6



H

L

K

J

C

15848

15850

15846

15848

28

I x 3



V x 3



W x 2





4x30

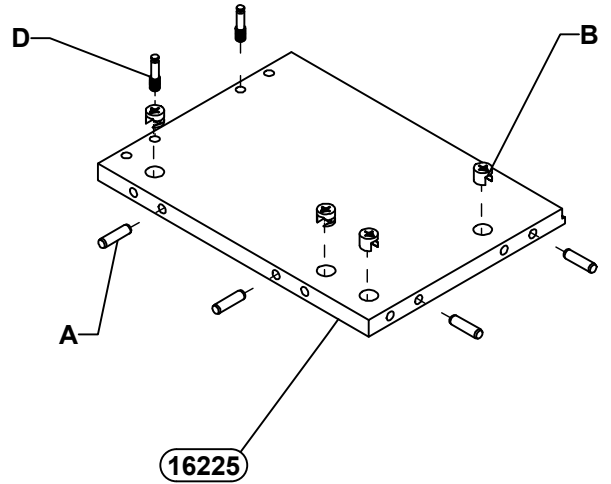
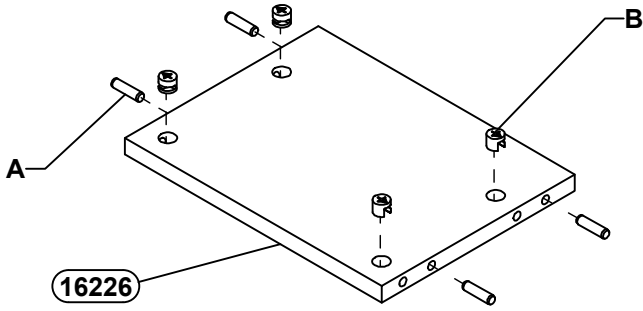
W

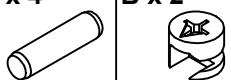
I

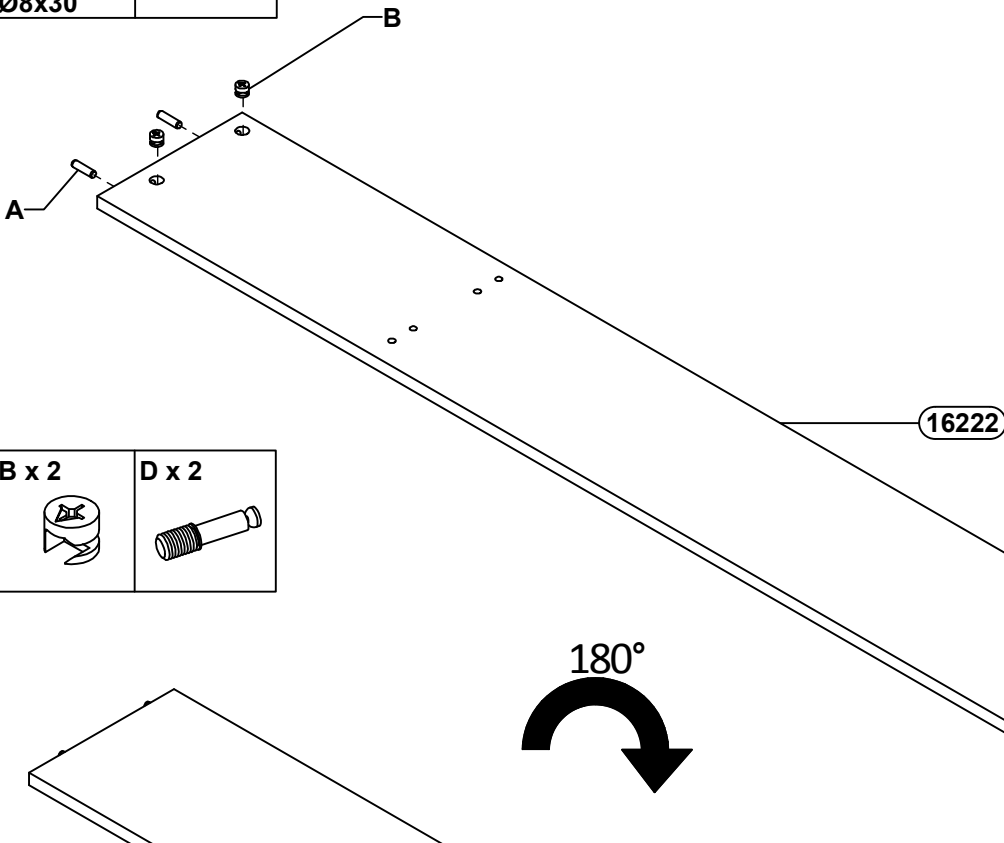
V

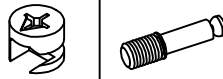
29 A x 4 B x 4

 Ø8x30

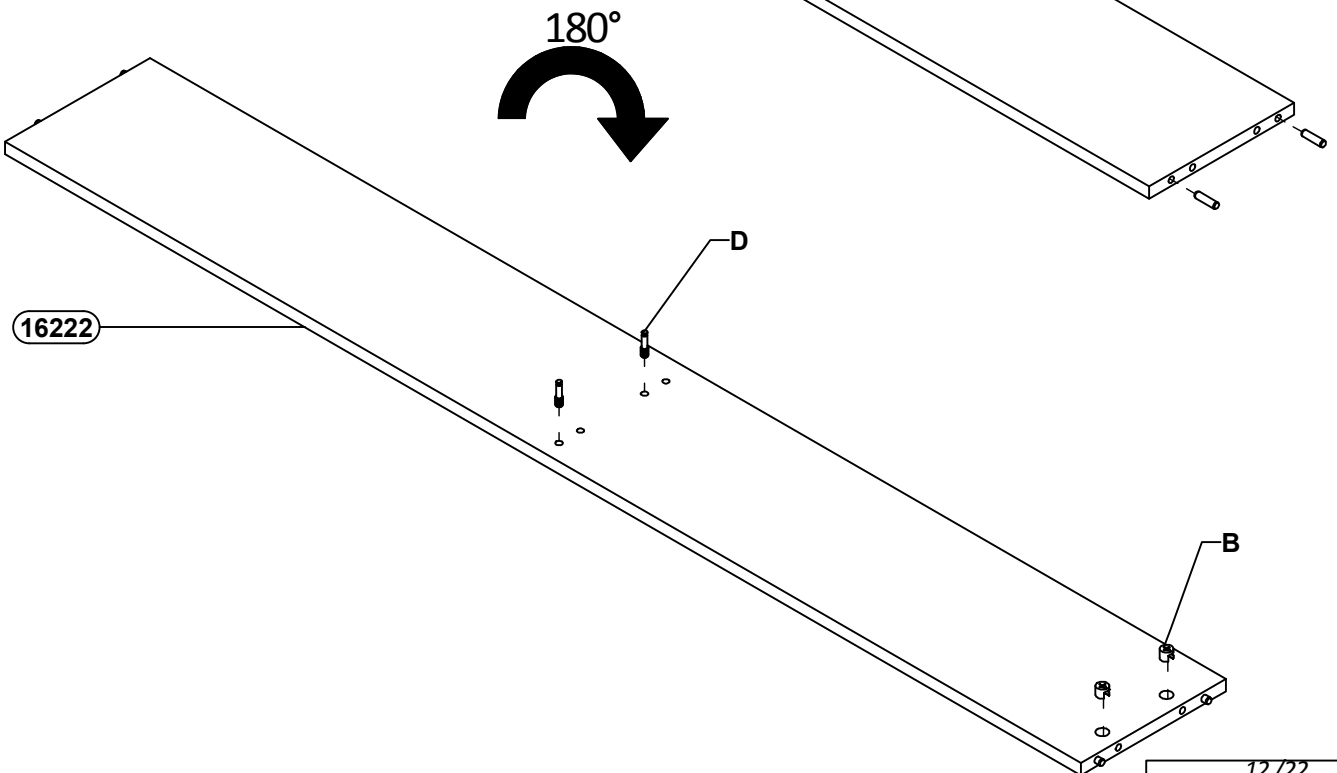
30 A x 4 B x 4 D x 2

 Ø8x30



31 A x 4 B x 2

 Ø8x30

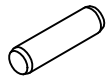


32 B x 2 D x 2




33

A x 4

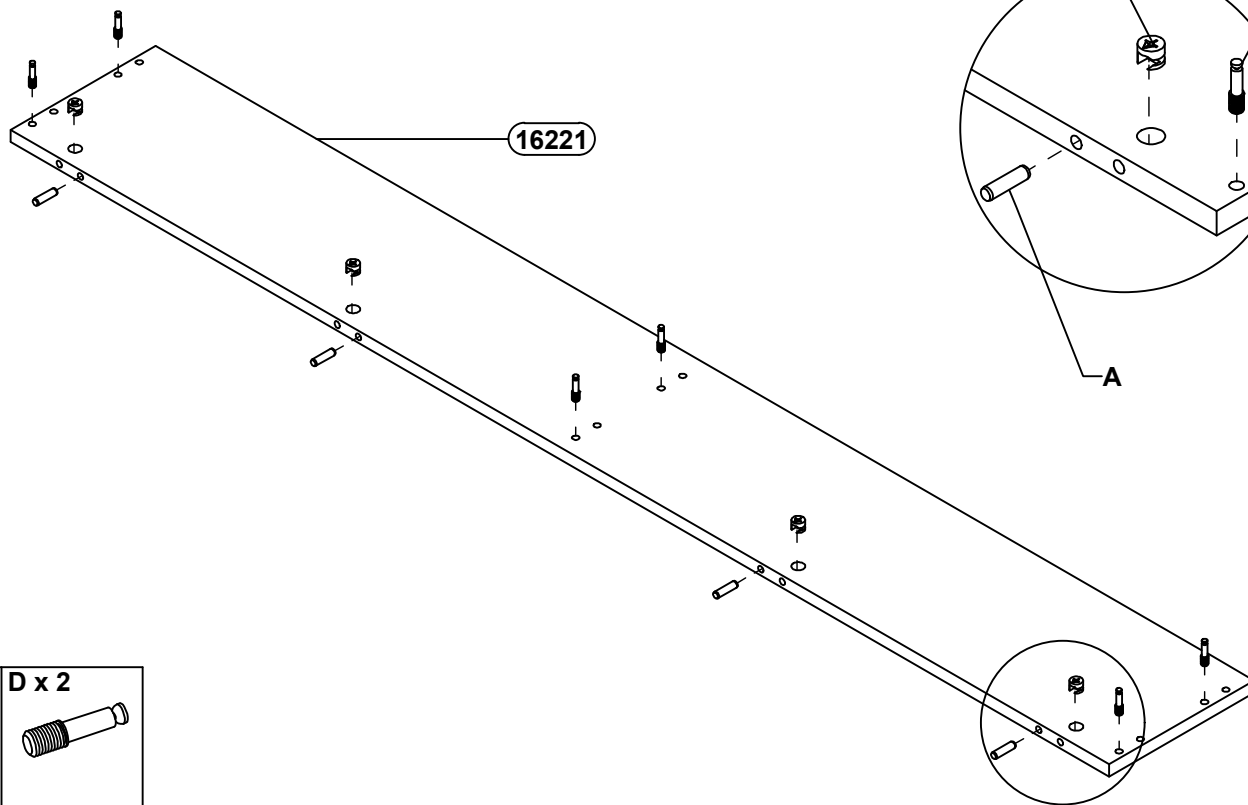
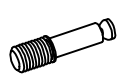


Ø8x30

B x 4

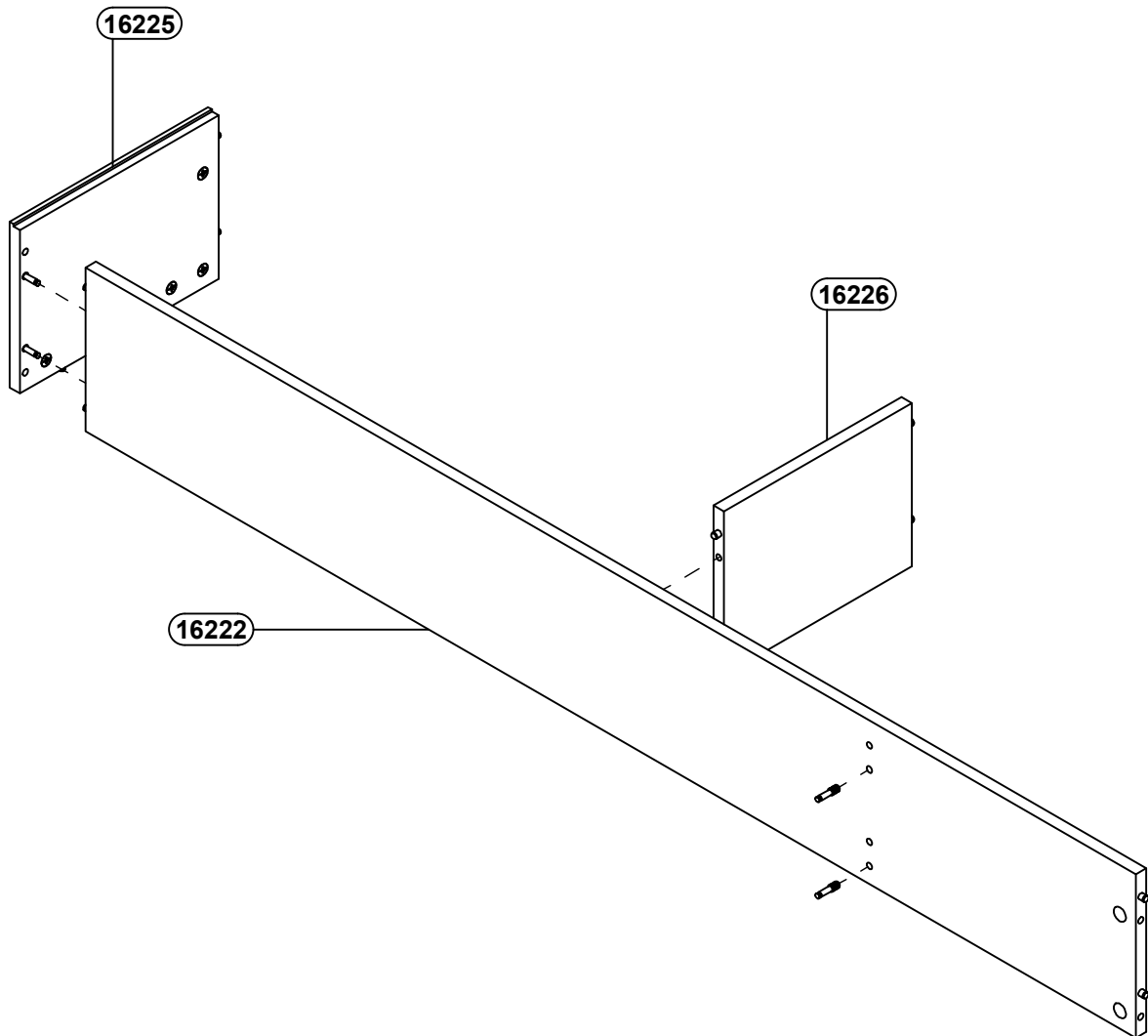
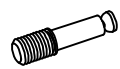


D x 6

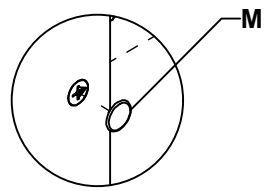
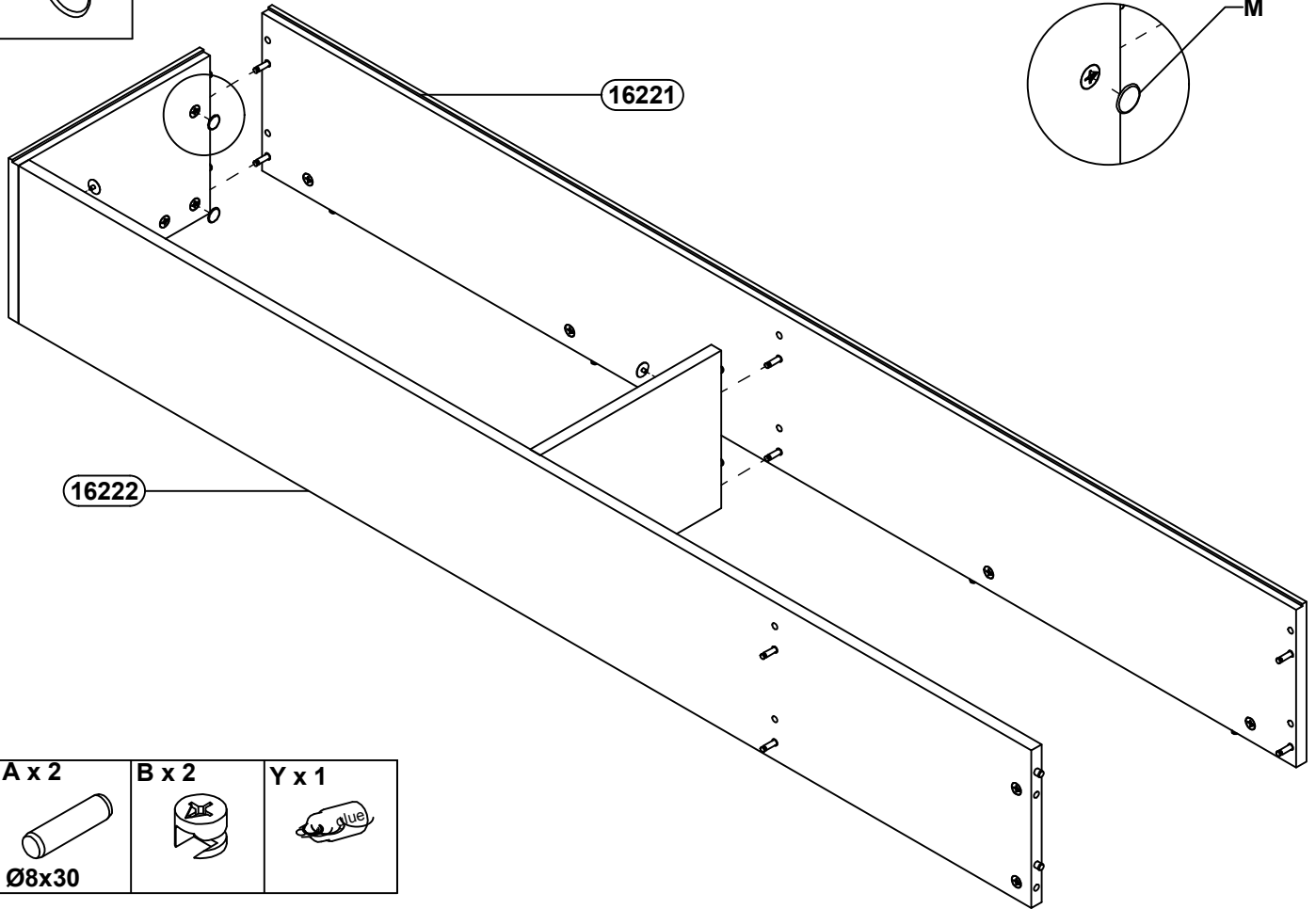


34

D x 2

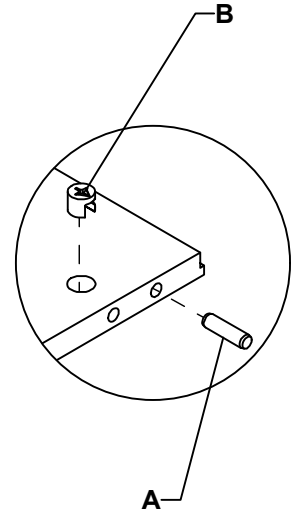
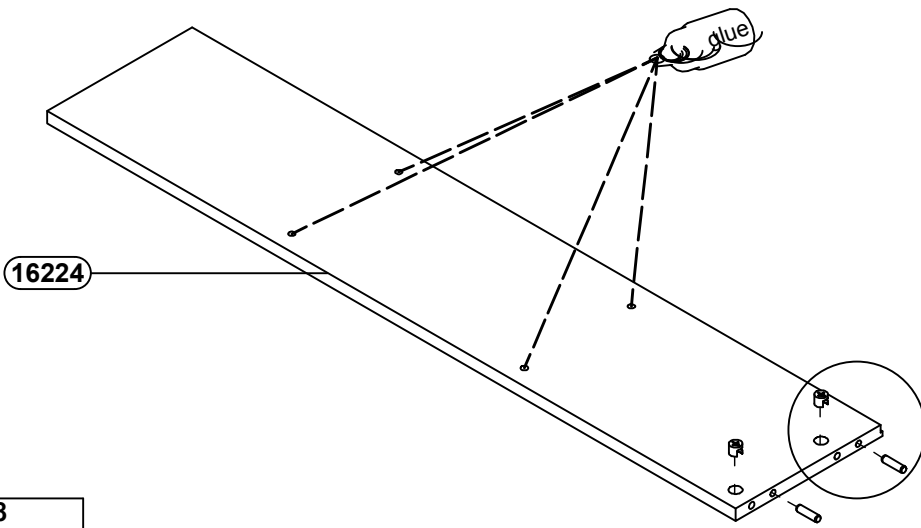


35 M x 8



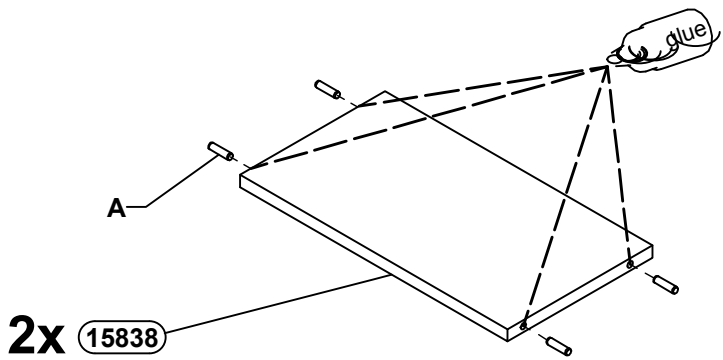
36 A x 2 B x 2 Y x 1

Ø8x30

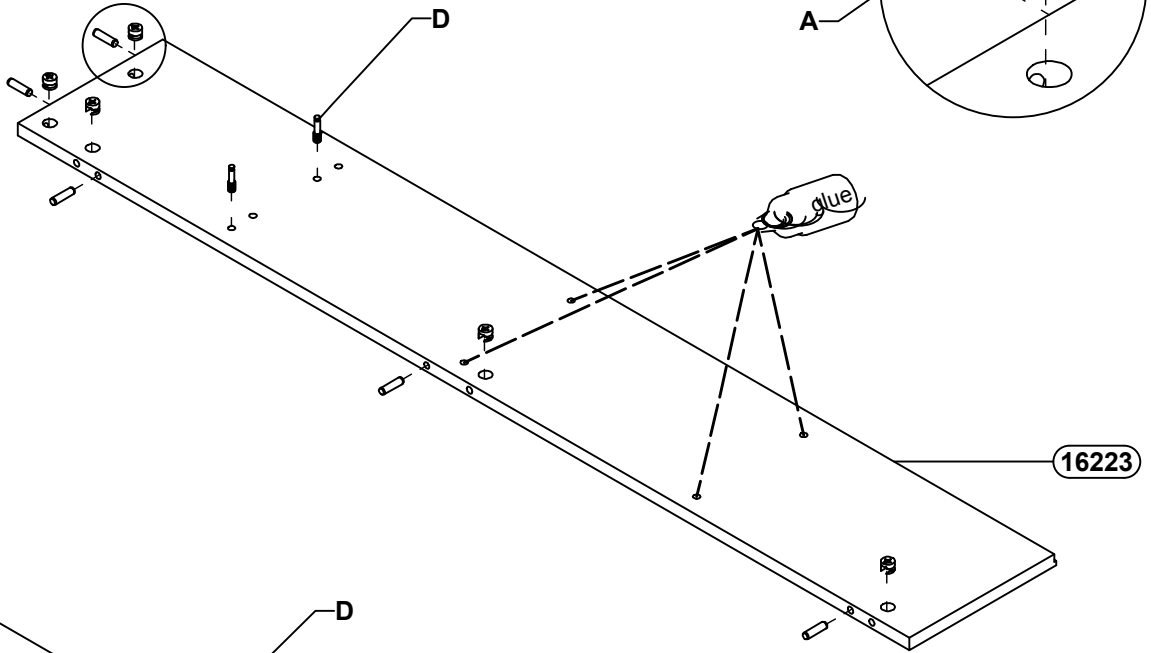
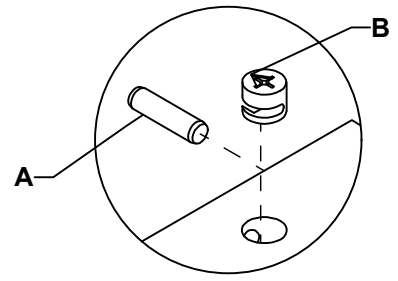
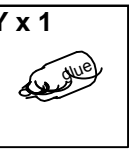
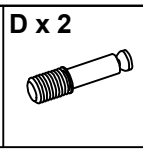
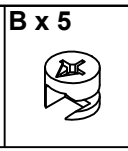
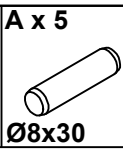


37 A x 8

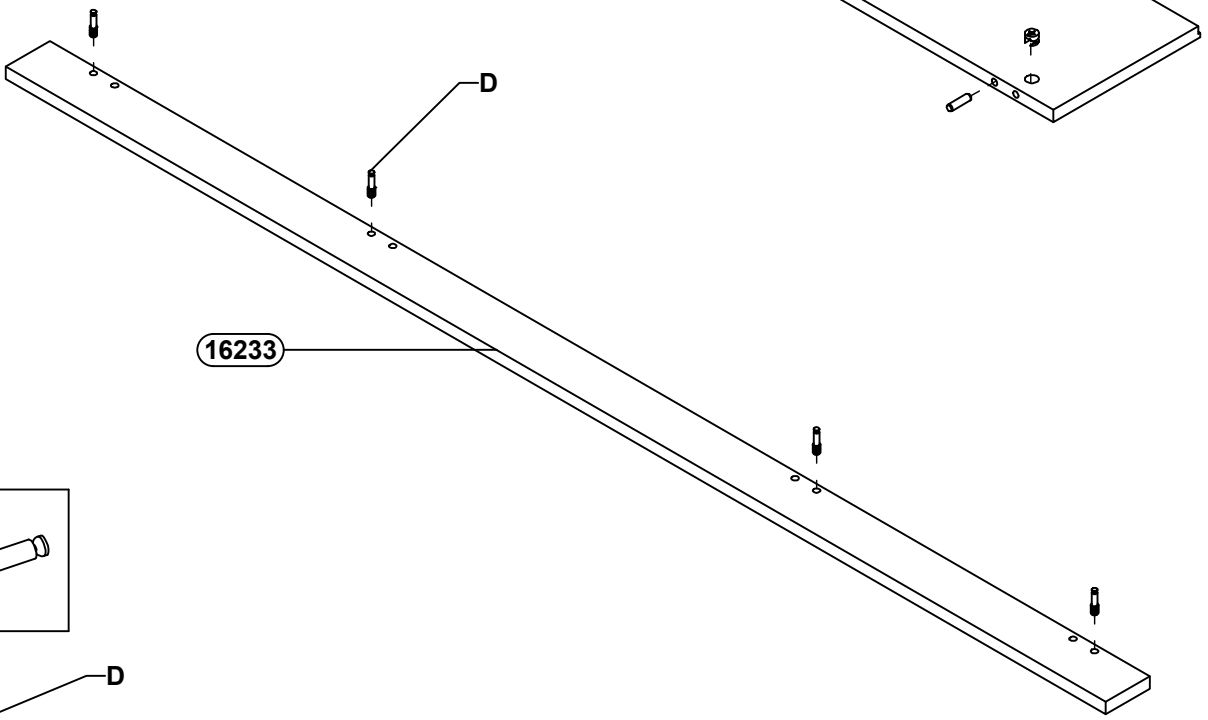
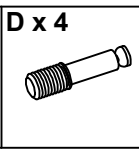
Ø8x30



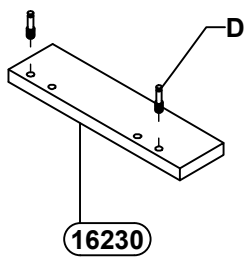
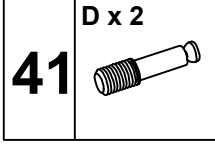
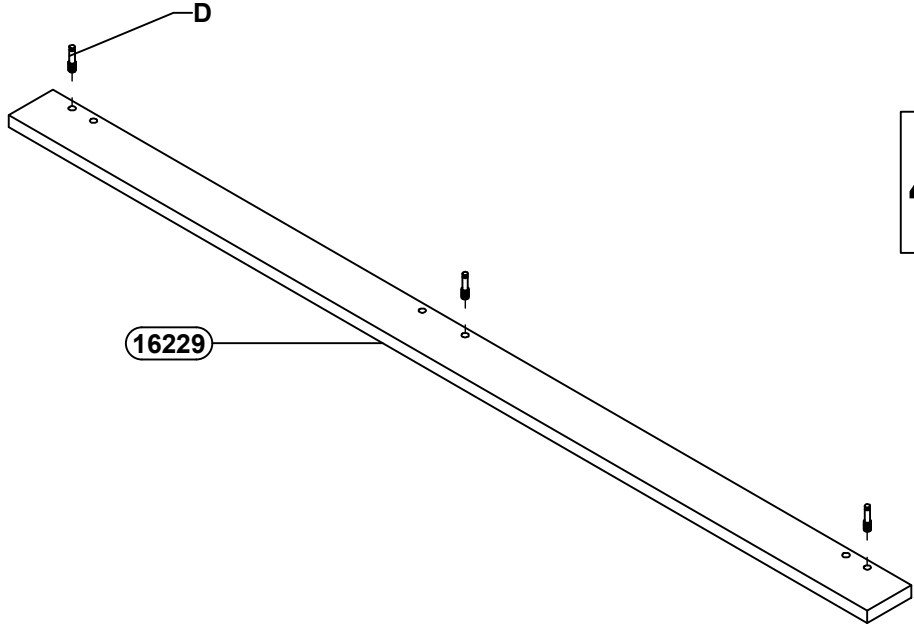
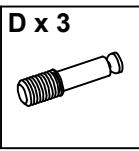
38



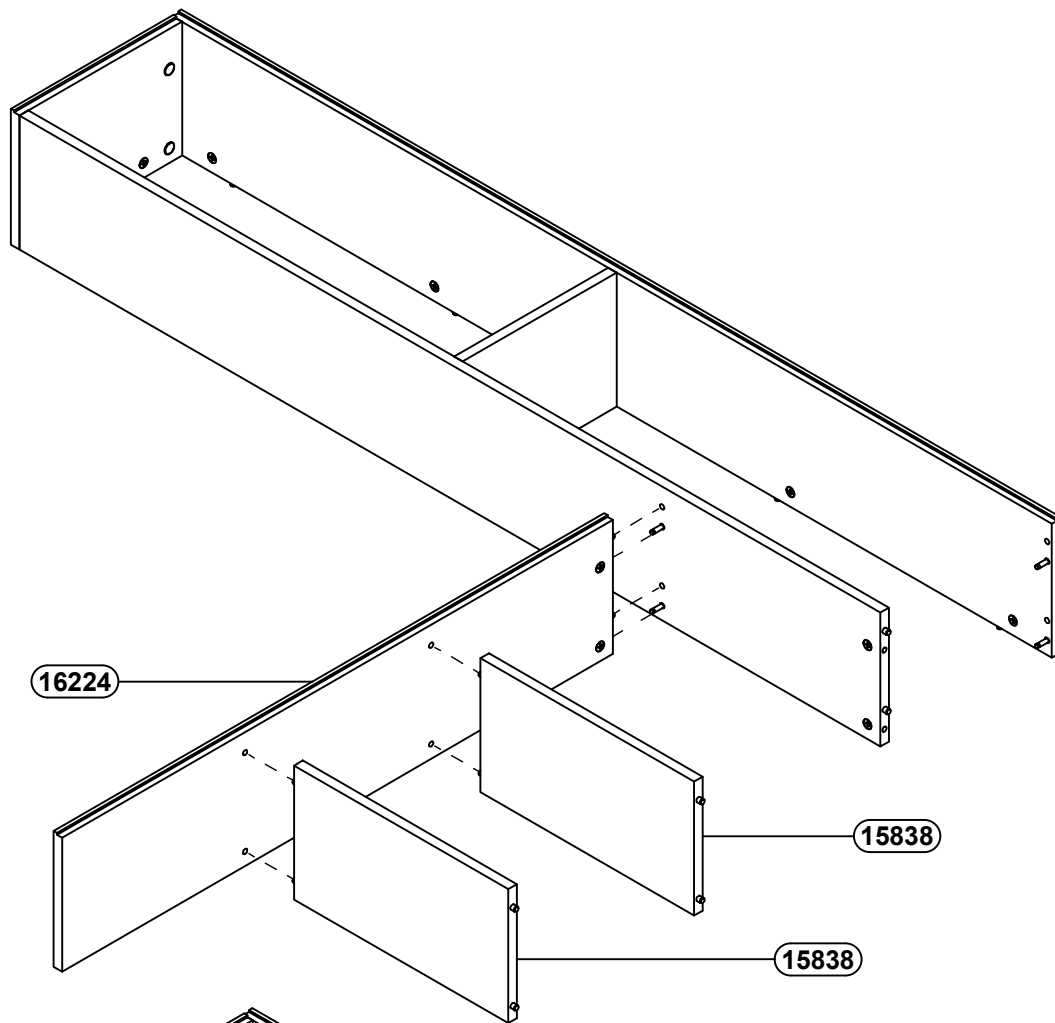
39



40

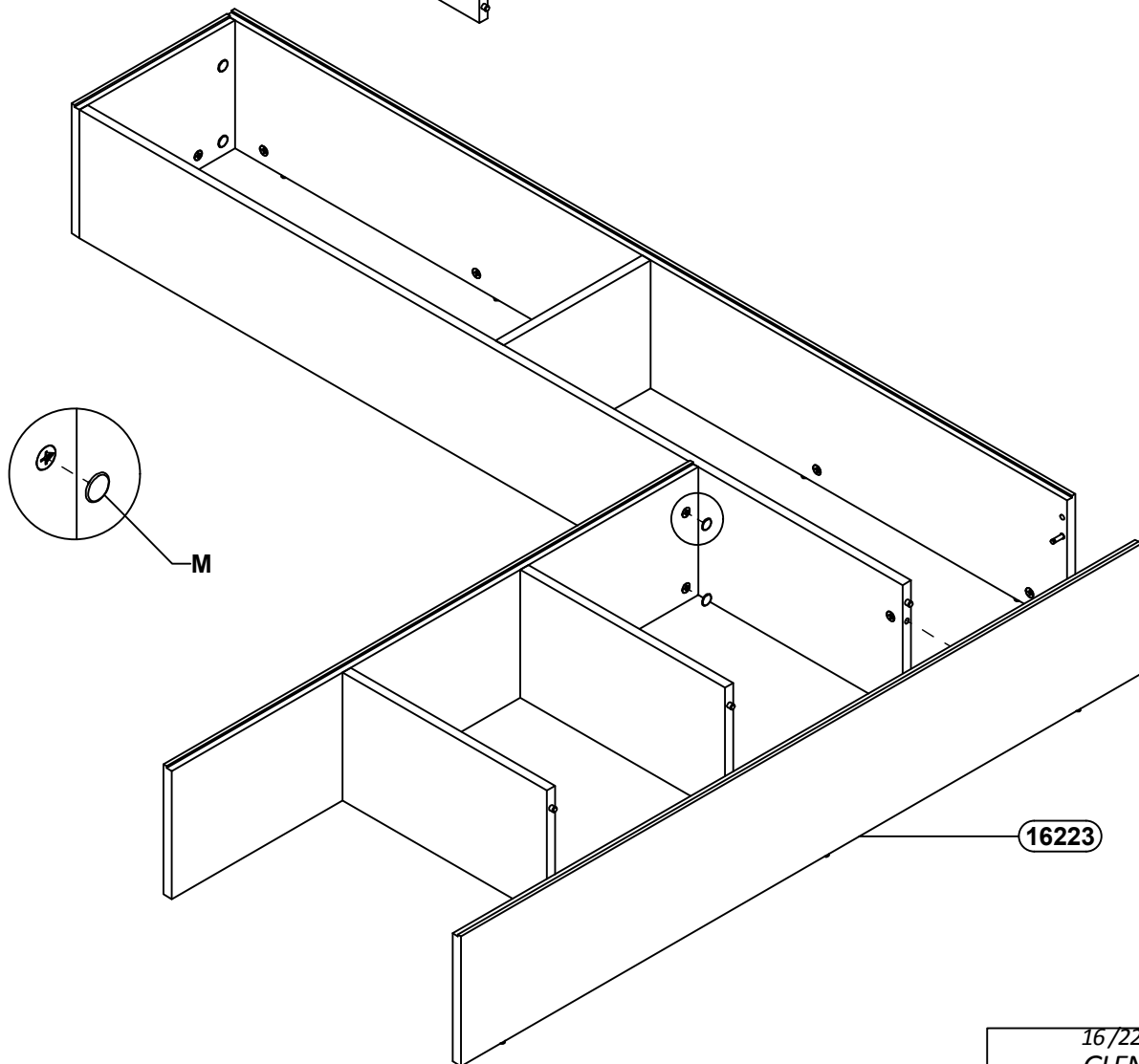


42

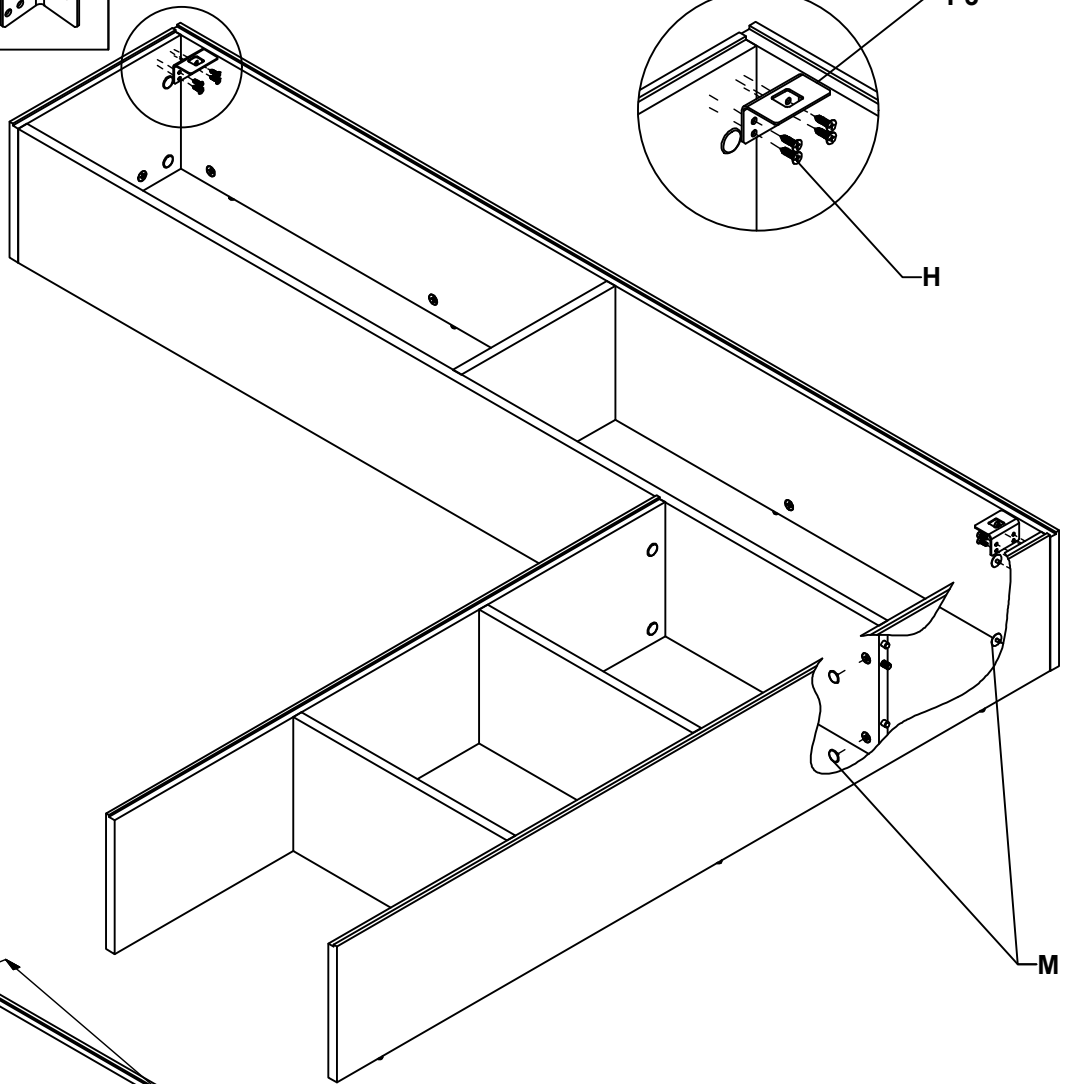
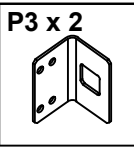


43

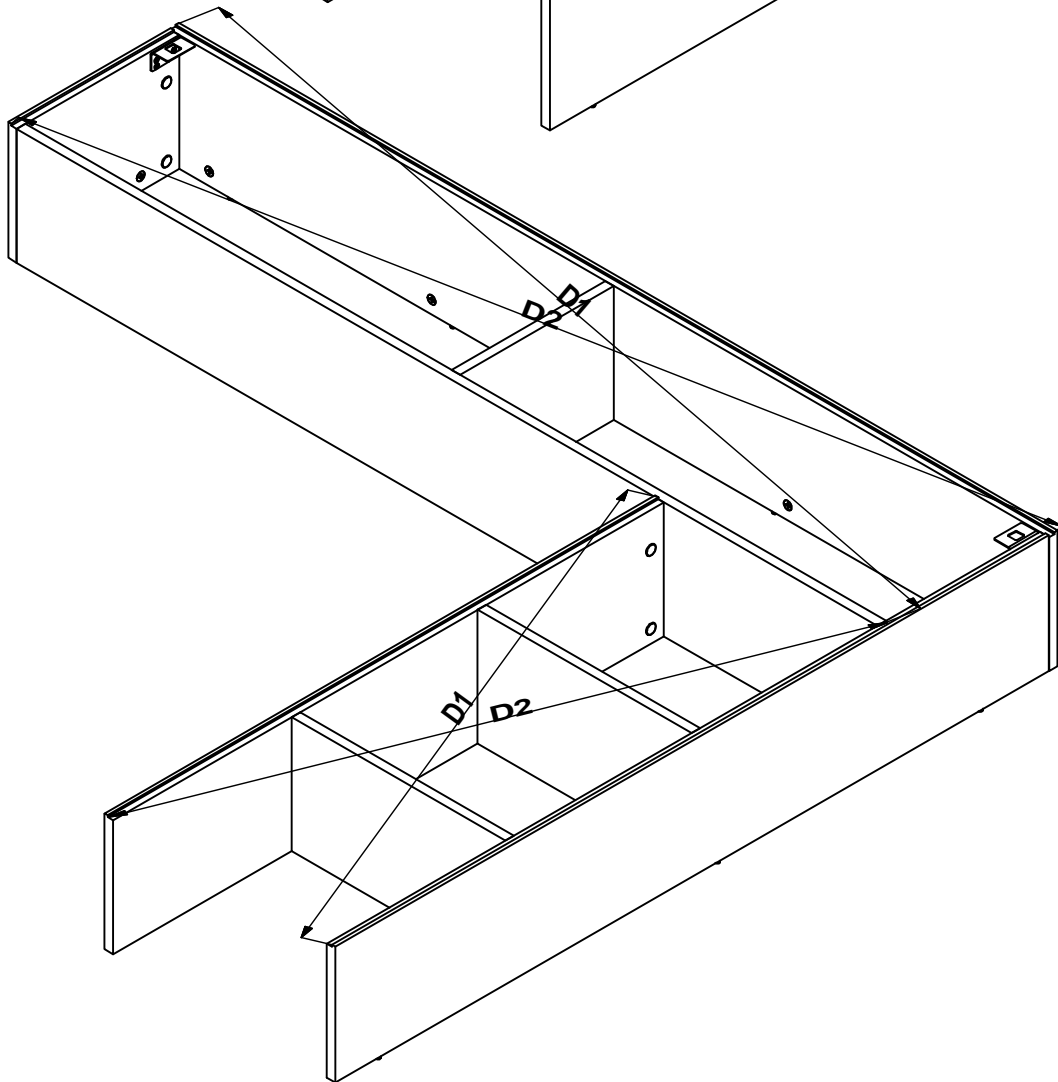
M x 2



44



45



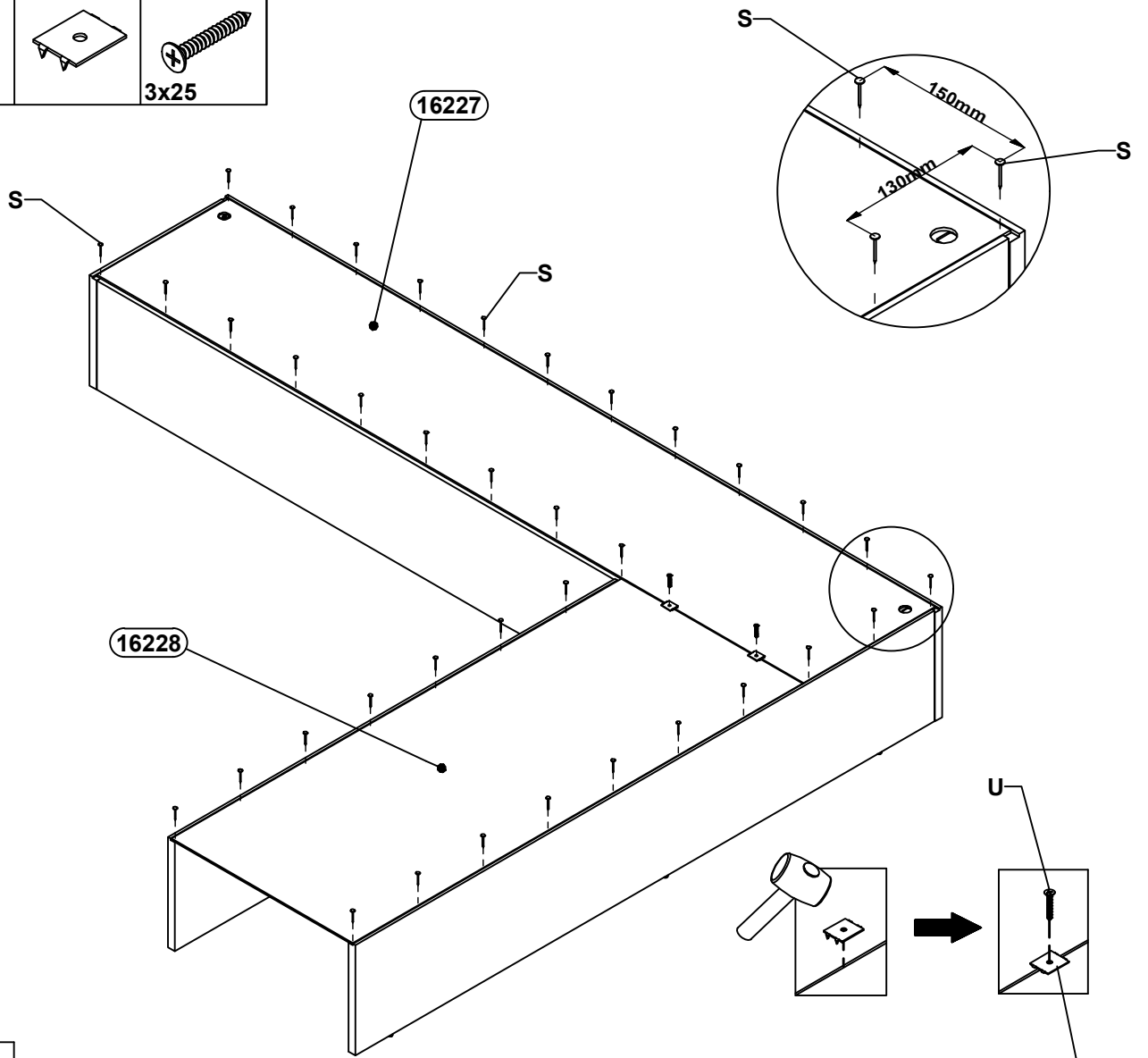
D1=D2

46

S x 37
1.6 x 25

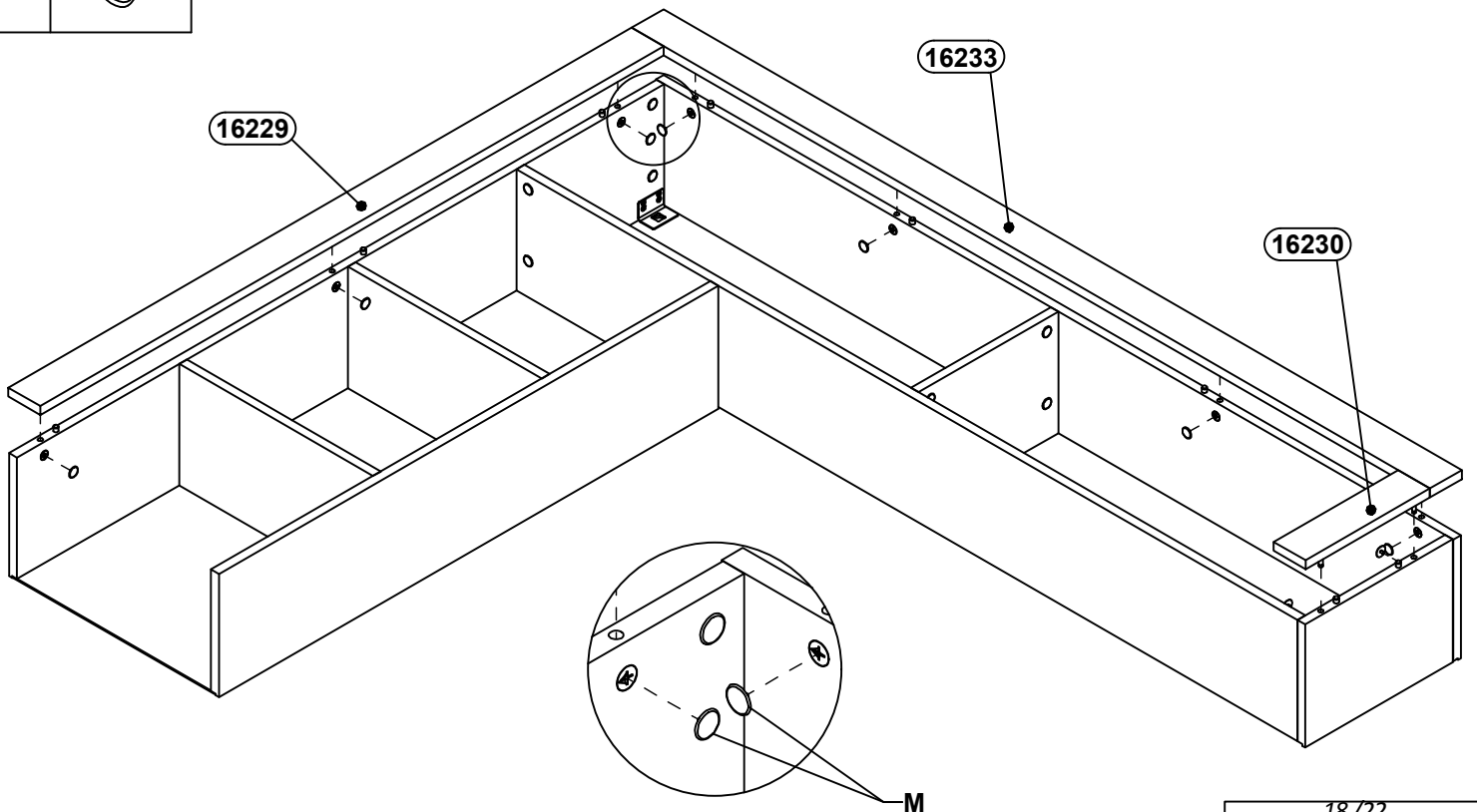
T x 2

U x 2
3x25



47

M x 9



48

Q x 2



R x 2



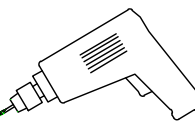
P x 2



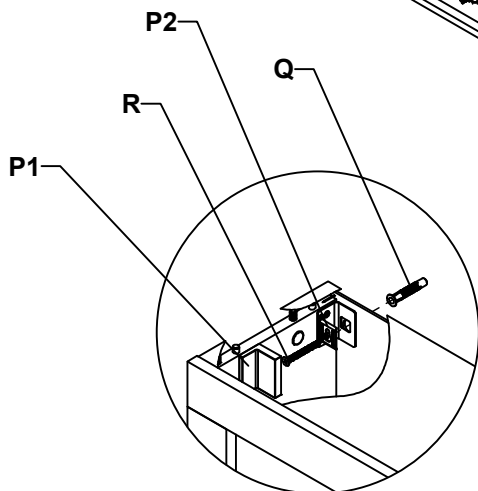
P1
P2

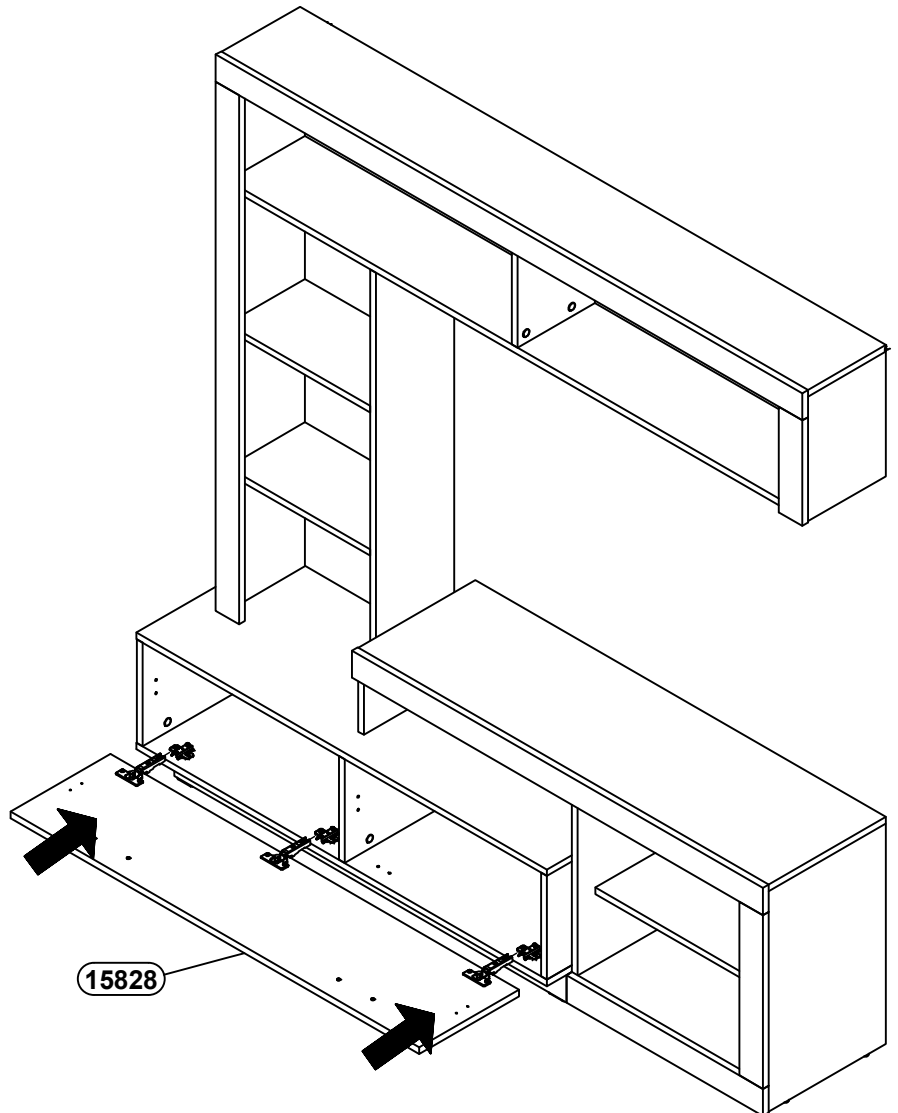
6x60

Ø10






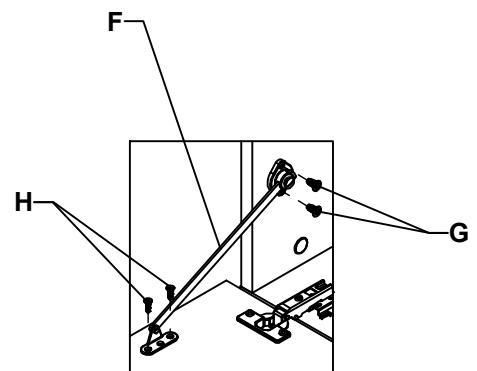
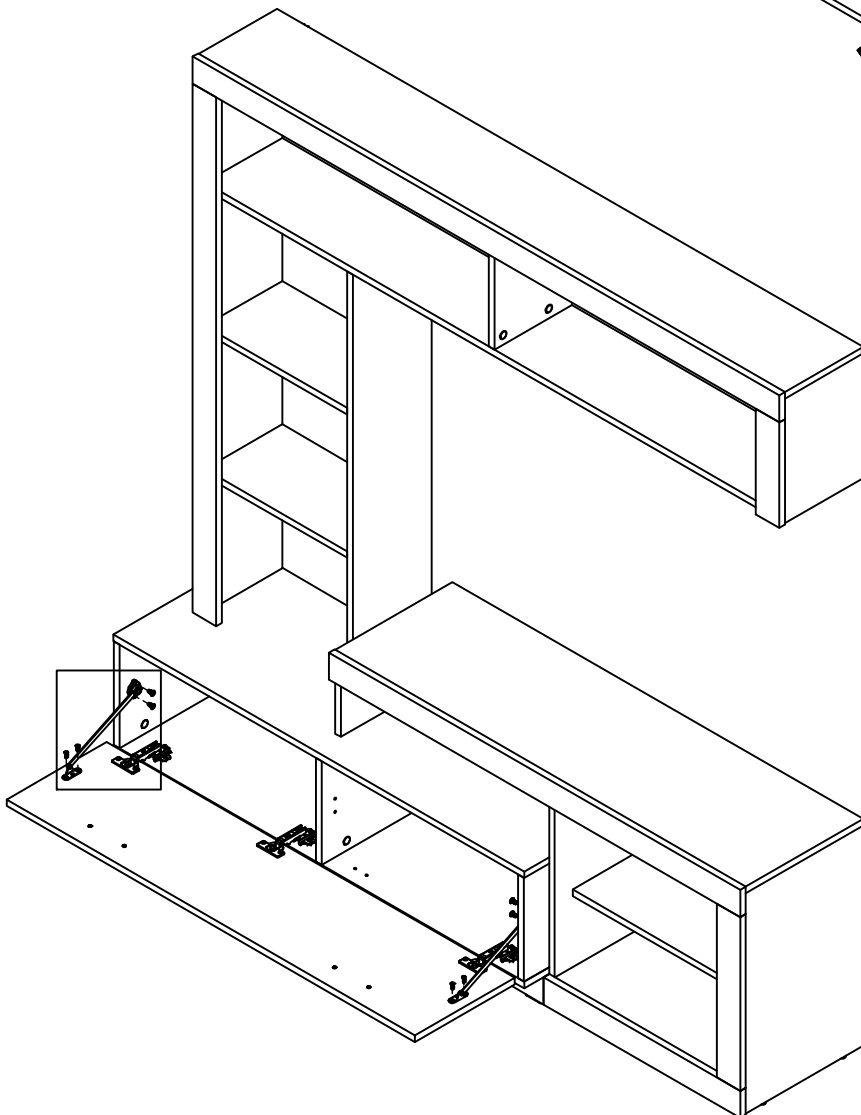
1570mm

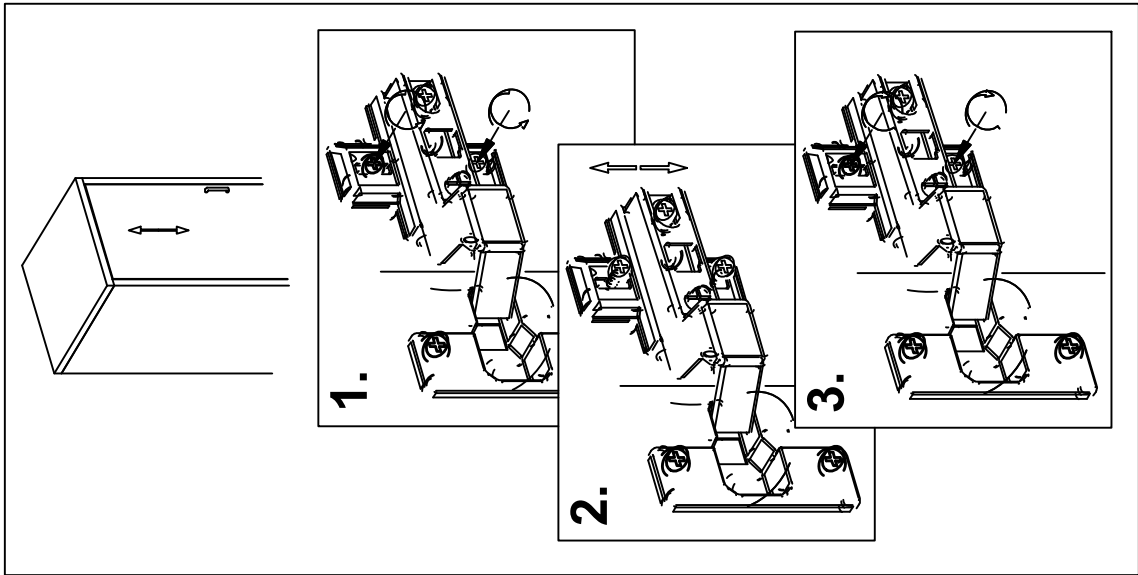
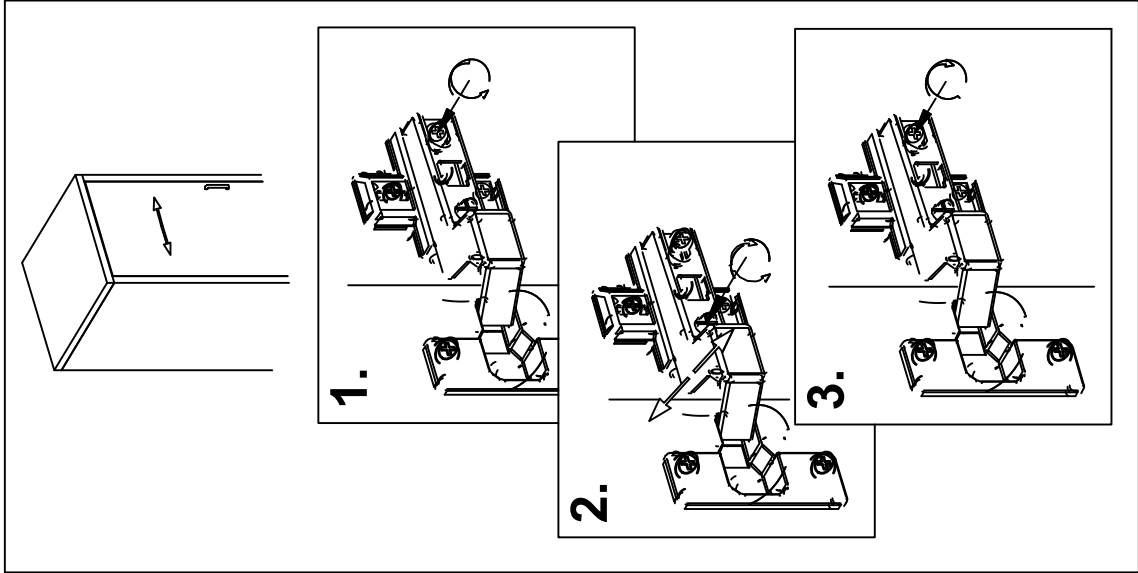
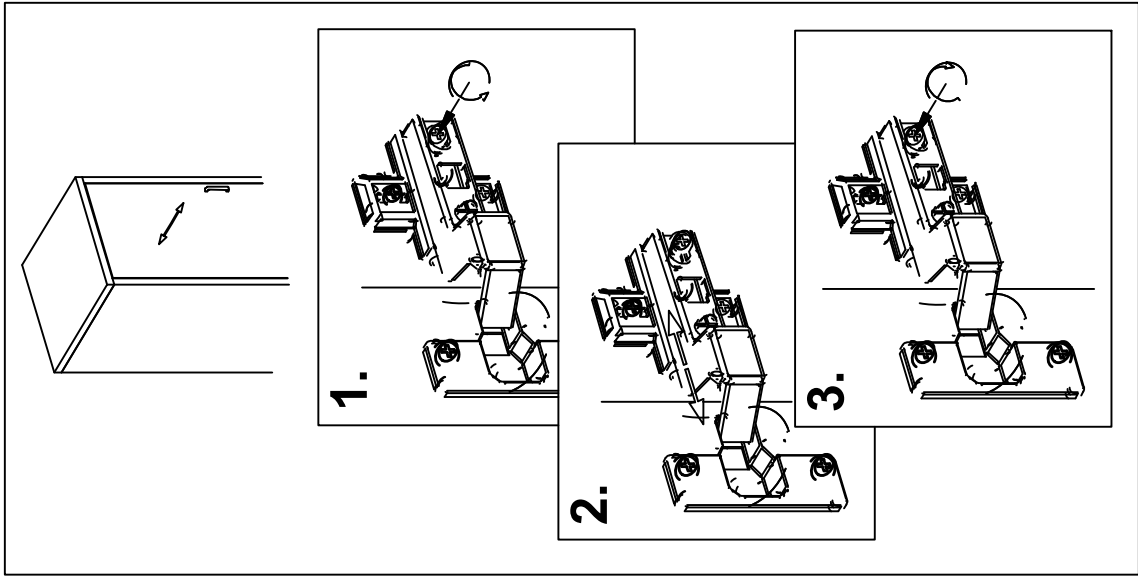




50

F x 2 	G x 4  Ø6.3x13	H x 4  4x16
---	--	---





**RS ME**

Dostavljeni plastični tiplovi su namenjeni za ugradnju na standardan zid od cigle.
Pre ugradnje korisnik je dužan da proveriti da li dos tavljeni tiplovi odgovaraju vrsti zida na koji je predviđena ugradnja.
Ukoliko tiplovi ne odgovaraju zidu kupac je u obavezi da u specijalizovanoj radnji sam nabavi odgovarajuće tiplove.

DE AT CH

Die gelieferten Plastikdübel sind zum Einbau in die standardmässige Ziegelwand bestimmt.
Vor dem Einbau ist der Benutzer verpflichtet zu prüfen, ob die gelieferten Dübel der für den Einbau vorgesehenen Wandart entsprechen.
Wenn die Dübel der Wand nicht entsprechen, ist der Kunde verpflichtet, im Fachhandel entsprechende Dübel selbst zu besorgen.

ES

Las clavijas plásticas que se incluyen están previstas para ser insertadas en un muro de ladrillo estándar.
Antes de instalarlas, el usuario debe verificar si las clavijas proporcionadas son adecuadas para el tipo de muro previsto en que se propone insertarlas.
Si las clavijas no son adecuadas para el muro, el comprador debe adquirir por sí mismo las clavijas correspondientes en una tienda especializada.

RUS BLR

Входящие в комплект поставки пластиковые дюбели предназначены для монтажа на стандартную кирпичную стену.
До начала монтажа пользователь должен проверить соответствие поставленных дюбелей типу стены, на которую предусмотрен монтаж.
Если дюбели не соответствуют типу стены, покупатель должен в обязательном порядке приобрести соответствующие дюбели в специализированном магазине.

EL

Οι πλαστικές βύδες που παρέχονται προορίζονται για ενσωμάτωση σε συνθησυσμένο τοίχο από τούβλα.
Πριν από την ενσωμάτωση, ο χρήστης οφείλει να ελέγξει εάν οι βύδες που παρέχονται αντιστοιχούν στον τύπο του τοίχου στον οποίο προβλέπεται η ενσωμάτωση.
Εάν οι βύδες δεν ταιριάζουν στον τοίχο, ο αγοραστής υποχρεούται να προμηθευθεί κατάλληλες σε εξειδικευμένο κατάστημα.

BG

Доставените пластмасови дюбели са направени за вграждане в стандартна тухлена стена. Преди вграждането, ползвателят е длъжен да провери дали доставените дюбели съответстват на стената, за която са предвидени за вграждане. Ако дюбелите не съответстват на стената на купувача, то той задължително трябва да закупи съответни дюбели от специализирания магазин.

SL

Dostavljeni plastični nosilci so namenjeni za montažo na standardni zid iz opeke. Pred montažo je uporabnik dolžan preveriti, ali dostavljeni nosilci ustrezajo vrsti zidu, na katerem je predvidena montaža. V kolikor nosilci niso primerni, je kupec dolžan sam pri specializiranemu prodajalcu priskrbeti nosilce, ki ustrezajo montaži.

MK

Доставените пластични типли наменети се за прикачување на стандарден ѕид од цигла. Пред прикачувањето корисникот е должен да провери дали доставените типли одговараат на видот на ѕидот на кој е предвидено прикачувањето. Доколку типлите не одговараат купувачот е должен сам да набави во специјализирана продавница типли кои одговараат.

**UK**

Delivered plastic plugs are intended for fitting on a standard brick wall.
Before fitting, the buyer needs to check if the delivered plugs are suitable for the wall they are foreseen for.
If the plugs are not suitable for the wall, buyers have to visit a specialized store and get suitable plugs by themselves.

FR CH

Les chevilles en plastique fournies sont conçues à l'installation sur le mur standard en briques.
Avant l'installation, l'utilisateur est obligé à vérifier si les chevilles fournies correspondent bien au type de mur prévu pour l'installation.
Si les chevilles ne correspondent pas bien au mur, l'acheteur est obligé à assurer lui-même les chevilles correspondantes dans un magasin spécialisé.

IT CH

I tasselli di plastica consegnati sono destinati al montaggio su un muro di mattoni standard.
Prima del loro montaggio, l'acquirente deve controllare se i tasselli forniti sono adatti per la parete su cui si prevede di installarli.
Se i tasselli non sono adatti per questo tipo di parete, l'acquirente è tenuto ad acquistare i tasselli adeguati presso un negozio specializzato.

CZ SK

Dodané plastové hmoždinky jsou určeny pro montáž na standardní cihlovou stěnu. Před začátkem montáže, kupující je povinen dohlédnout na správnost typu dodaných hmoždinek, vzhledem na typ stěny určené k montáži.
Pokud hmoždinky dodané výrobcem neodpovídají typu stěny určené k montáži, kupující je povinen pořídit si správný typ ve specializované prodejně.

RO

Tiplurile din plastic transmise sunt prevăzute exclusiv pentru pereții standard din cărămidă. Înainte de instalare beneficiarul este obligat să verifice dacă tiplurile transmise corespund peretelui pe care se prevede instalarea. În cazul în care tiplurile nu corespund peretelui, cumpărătorul este obligat să achiziționeze singur tiplurile corespunzătoare din magazinele specializate.

HU

A kézbesített műanyag tiplik standard téglafalra való beépítésre szolgálnak. Beépítés előtt a felhasználó köteles leellenőrizni, hogy a tiplik megfelelnek-e a falfajtájának, amelyre a beépítést szánták.
Ha a tiplik nem felelnek meg, a vásárló köteles a megfelelőket szaküzletben beszerezni.

HR BIH

Dostavljeni plastični tiplovi su namijenjeni za ugradnju na standardan zid od cigle. Prije ugradnje korisnik je dužan da provjeri da li dostavljeni tiplovi odgovaraju vrsti zida na koji je predviđena ugradnja.
Ukoliko tiplovi ne odgovaraju zidu kupac je u obavezi da u specijaliziranoj radnji sam nabavi odgovarajuće tiplove.

AL

Ankorat e dhëna plastike janë të dizajnuara për instalim në mur standard me tulla. Para instalimit përdoruesi duhet të verifikojë nëse ankorat e dërguara iu përshtaten llojit të murit në të cilin është parashikuar të bëhet instalimi.
Nëse ankorat nuk iu përshtaten murit, blerësi është i obliguar që vetë të blejë ankorat e duhura në shitoren e specializuar.